

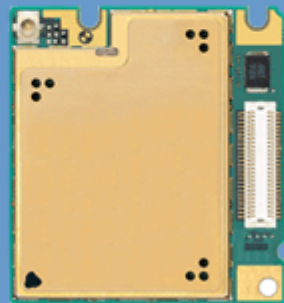

CINTERION
WIRELESS MODULES

MC55i

Version: 01.200a
DocId: MC55i_HD_v01.200a



Hardware Interface Description

Document Name:	MC55i Hardware Interface Description
Version:	01.200a
Date:	2009-3-25
DocId:	MC55i_HD_v01.200a
Status	Confidential / Released
Supported Products:	MC55i

GENERAL NOTE

THE USE OF THE PRODUCT INCLUDING THE SOFTWARE AND DOCUMENTATION (THE "PRODUCT") IS SUBJECT TO THE RELEASE NOTE PROVIDED TOGETHER WITH PRODUCT. IN ANY EVENT THE PROVISIONS OF THE RELEASE NOTE SHALL PREVAIL. THIS DOCUMENT CONTAINS INFORMATION ON CINTERION PRODUCTS. THE SPECIFICATIONS IN THIS DOCUMENT ARE SUBJECT TO CHANGE AT CINTERION'S DISCRETION. CINTERION WIRELESS MODULES GMBH GRANTS A NON-EXCLUSIVE RIGHT TO USE THE PRODUCT. THE RECIPIENT SHALL NOT TRANSFER, COPY, MODIFY, TRANSLATE, REVERSE ENGINEER, CREATE DERIVATIVE WORKS; DISASSEMBLE OR DECOMPILE THE PRODUCT OR OTHERWISE USE THE PRODUCT EXCEPT AS SPECIFICALLY AUTHORIZED. THE PRODUCT AND THIS DOCUMENT ARE PROVIDED ON AN "AS IS" BASIS ONLY AND MAY CONTAIN DEFICIENCIES OR INADEQUACIES. TO THE MAXIMUM EXTENT PERMITTED BY APPLICABLE LAW, CINTERION WIRELESS MODULES GMBH DISCLAIMS ALL WARRANTIES AND LIABILITIES. THE RECIPIENT UNDERTAKES FOR AN UNLIMITED PERIOD OF TIME TO OBSERVE SECRECY REGARDING ANY INFORMATION AND DATA PROVIDED TO HIM IN THE CONTEXT OF THE DELIVERY OF THE PRODUCT. THIS GENERAL NOTE SHALL BE GOVERNED AND CONSTRUED ACCORDING TO GERMAN LAW.

Copyright

Transmittal, reproduction, dissemination and/or editing of this document as well as utilization of its contents and communication thereof to others without express authorization are prohibited. Offenders will be held liable for payment of damages. All rights created by patent grant or registration of a utility model or design patent are reserved.

Copyright © 2009, Cinterion Wireless Modules GmbH

Trademark Notice

Microsoft and Windows are either registered trademarks or trademarks of Microsoft Corporation in the United States and/or other countries. All other registered trademarks or trademarks mentioned in this document are property of their respective owners.

Contents

0	Document History	8
1	Introduction	10
1.1	Related documents	10
1.2	Terms and Abbreviations	11
1.3	Regulatory and Type Approval Information	14
1.3.1	Directives and Standards	14
1.3.2	SAR Requirements Specific to Portable Mobiles	16
1.3.3	Safety Precautions	17
2	Product Concept	18
2.1	MC55i Key Features at a Glance	18
2.2	MC55i System Overview	20
2.3	Circuit Concept	21
3	Application Interface	22
3.1	Operating Modes	23
3.2	Power Supply	24
3.2.1	Minimizing Power Losses	24
3.2.2	Measuring the Supply Voltage (V_{BATT+})	25
3.2.3	Monitoring Power Supply	25
3.3	Power Up / Power Down Scenarios	26
3.3.1	Turn on MC55i	26
3.3.1.1	Turn on MC55i using the Ignition Line IGT (Power on)	26
3.3.1.2	Timing of the Ignition Process	27
3.3.1.3	Turn on MC55i using the POWER Signal	28
3.3.1.4	Turn on MC55i using the RTC (Alarm Mode)	28
3.3.2	Turn off MC55i	30
3.3.2.1	Turn off MC55i using AT Command	30
3.3.2.2	Emergency Shutdown using EMERGOFF Pin	31
3.3.3	Automatic Shutdown	32
3.3.3.1	Thermal Shutdown	32
3.3.3.2	Deferred Shutdown at Extreme Temperature Conditions	33
3.3.3.3	Undervoltage Shutdown	34
3.3.3.4	Overvoltage Shutdown	34
3.4	Automatic GPRS Multislot Class Change	34
3.5	Charging Control	35
3.5.1	Hardware Requirements	35
3.5.2	Software Requirements	35
3.5.3	Battery Pack Characteristics	36
3.5.4	Batteries Tested for Use with MC55i	37
3.5.5	Implemented Charging Technique	38
3.5.6	Operating Modes During Charging	39
3.5.7	Charger Requirements	40
3.5.8	Switch off during Charge-only Mode	41

3.6	Power Saving.....	42
3.6.1	No Power Saving (AT+CFUN=1).....	42
3.6.2	NON-CYCLIC SLEEP Mode (AT+CFUN=0).....	42
3.6.3	CYCLIC SLEEP Mode (AT+CFUN=5, 6, 7, 8).....	43
3.6.4	CYCLIC SLEEP Mode AT+CFUN=9.....	43
3.6.5	Timing of the CTS Signal in CYCLIC SLEEP Modes.....	43
3.6.6	Wake up MC55i from SLEEP Mode.....	45
3.6.6.1	Wake-up via RTS0 and RTS1 (if AT+CFUN=0 or AT+CFUN=9).....	46
3.7	Summary of State Transitions (except SLEEP Mode).....	47
3.8	RTC Backup.....	48
3.9	Serial Interface ASC0.....	49
3.10	Serial Interface ASC1.....	51
3.11	Audio interfaces.....	52
3.11.1	Microphone Circuit.....	53
3.11.2	Speech Processing.....	54
3.11.3	DAI Timing.....	54
3.12	SIM Interface.....	55
3.12.1	Requirements for using the CCIN Pin.....	56
3.12.2	Design Considerations for SIM Card Holder.....	57
3.13	Control signals.....	58
3.13.1	Inputs.....	58
3.13.2	Outputs.....	58
3.13.2.1	Synchronization Signal.....	58
3.13.2.2	Using the SYNC Pin to Control a Status LED.....	59
3.13.2.3	Behavior of the RING0 Line (ASC0 Interface only).....	61
4	Antenna Interface.....	62
4.1	Antenna Installation.....	62
4.1.1	Antenna Pad.....	64
4.1.1.1	Suitable Cable Types.....	64
4.1.2	Hirose Antenna Connector.....	65
5	Electrical, Reliability and Radio Characteristics.....	69
5.1	Absolute Maximum Ratings.....	69
5.2	Operating Temperatures.....	70
5.3	Storage Conditions.....	71
5.4	Reliability Characteristics.....	72
5.5	Electrical Specifications of the Application Interface.....	73
5.6	Power Supply Ratings.....	80
5.7	Electrical Characteristics of the Voiceband Part.....	81
5.7.1	Setting Audio Parameters by AT Commands.....	81
5.7.2	Audio Programming Model.....	82
5.7.3	Characteristics of Audio Modes.....	83
5.7.4	Voiceband Receive Path.....	84
5.7.5	Voiceband Transmit Path.....	85



- 5.8 Air Interface..... 86
- 5.9 Electrostatic Discharge 87
- 6 Mechanics..... 88**
 - 6.1 Mechanical Dimensions of MC55i..... 88
 - 6.2 Mounting MC55i onto the Application Platform..... 90
 - 6.3 Board-to-Board Connector..... 91
 - 6.3.1 Mechanical Dimensions of the Hirose DF12 Connector 92
 - 6.3.2 Adapter Cabling 92
- 7 Reference Approval 93**
 - 7.1 Reference Equipment for Type Approval..... 93
 - 7.2 Compliance with FCC Rules and Regulations 94
- 8 Sample Application..... 95**
- 9 Appendix..... 97**
 - 9.1 List of Parts and Accessories..... 97
 - 9.2 Mounting Advice Sheet..... 98

Tables

Table 1:	Directives	14
Table 2:	Standards of North American type approval	14
Table 3:	Standards of European type approval.....	14
Table 4:	Requirements of quality	15
Table 5:	Standards of the Ministry of Information Industry of the People's Republic of China	15
Table 6:	Toxic or hazardous substances or elements with defined concentration limits	16
Table 7:	Overview of operating modes	23
Table 8:	AT commands available in Alarm mode.....	28
Table 9:	Temperature dependent behavior.....	33
Table 10:	Specifications of battery packs suitable for use with MC55i	37
Table 11:	Comparison Charge-only and Charge mode	39
Table 12:	AT commands available in Charge-only mode	40
Table 13:	Wake-up events in NON-CYCLIC and CYCLIC SLEEP modes	45
Table 14:	State transitions of MC55i (except SLEEP mode)	47
Table 15:	DCE-DTE wiring of ASC0	50
Table 16:	DCE-DTE wiring of ASC1	51
Table 17:	Signals of the SIM interface (board-to-board connector)	55
Table 18:	Pin assignment of Molex SIM card holder on DSB45 Support Box	57
Table 19:	Input control signals of the MC55i module.....	58
Table 20:	Coding of the status LED	59
Table 21:	ASC0 ring signal	61
Table 22:	Return loss	62
Table 23:	Product specifications of U.FL-R-SMT connector	65
Table 24:	Material and finish of U.FL-R-SMT connector and recommended plugs	66
Table 25:	Ordering information for Hirose U.FL Series.....	68
Table 26:	Absolute maximum ratings.....	69
Table 27:	Board / battery temperature	70
Table 28:	Ambient temperature according to IEC 60068-2 (without forced air circulation) .	70
Table 29:	Charging temperature	70
Table 30:	Storage conditions	71
Table 31:	Summary of reliability test conditions.....	72
Table 32:	Electrical description of application interface	74
Table 33:	Power supply ratings.....	80
Table 34:	Audio parameters adjustable by AT command	81
Table 35:	Voiceband characteristics (typical).....	83
Table 36:	Voiceband receive path.....	84
Table 37:	Voiceband transmit path	85
Table 38:	Air Interface.....	86
Table 39:	Measured electrostatic values.....	87
Table 40:	Ordering information DF12 series	91
Table 41:	Electrical and mechanical characteristics of the Hirose DF12C connector....	91
Table 42:	List of parts and accessories.....	97
Table 43:	Molex sales contacts (subject to change)	98
Table 44:	Hirose sales contacts (subject to change)	98

Figures

Figure 1:	MC55i system overview	20
Figure 2:	MC55i block diagram	21
Figure 3:	Power supply limits during transmit burst.....	25
Figure 4:	Position of the reference test points TP BATT+ and TP GND	25
Figure 5:	Power-on by ignition signal	27
Figure 6:	Deactivating GSM module by EMERGOFF signal.....	31
Figure 7:	Battery pack circuit diagram.....	36
Figure 8:	Charging process	38
Figure 9:	External circuit to switch off MC55i during charging	41
Figure 10:	Timing of CTS signal (example for a 2.12 s paging cycle).....	44
Figure 11:	Beginning of power saving if CFUN=5 or 7	44
Figure 12:	RTC supply from capacitor.....	48
Figure 13:	RTC supply from rechargeable battery	48
Figure 14:	RTC supply from non-chargeable battery	48
Figure 15:	Serial interface ASC0.....	49
Figure 16:	Serial interface ASC1.....	51
Figure 17:	Audio block diagram.....	52
Figure 18:	Schematic of microphone inputs	53
Figure 19:	DAI timing.....	54
Figure 20:	SIM card holder of DSB45 Support Box.....	57
Figure 21:	Pin numbers of Molex SIM card holder on DSB45 Support Box.....	57
Figure 22:	SYNC signal during transmit burst.....	58
Figure 23:	LED Circuit (Example).....	60
Figure 24:	Incoming voice call.....	61
Figure 25:	URC transmission	61
Figure 26:	Never use antenna connector and antenna pad at the same time	63
Figure 27:	Restricted area around antenna pad.....	63
Figure 28:	Mechanical dimensions of U.FL-R-SMT connector.....	65
Figure 29:	U.FL-R-SMT connector with U.FL-LP-040 plug	66
Figure 30:	U.FL-R-SMT connector with U.FL-LP-066 plug	66
Figure 31:	Specifications of U.FL-LP-(V)-040(01) plug	67
Figure 32:	Pin assignment	73
Figure 33:	Audio programming model.....	82
Figure 34:	MC55i – top view.....	88
Figure 35:	Mechanical dimensions of MC55i (all dimensions in millimeters)	89
Figure 36:	Hirose DF12C receptacle on MC55i	91
Figure 37:	Header Hirose DF12 series.....	91
Figure 38:	Mechanical dimensions of Hirose DF12 connector.....	92
Figure 39:	Reference equipment for approval.....	93
Figure 40:	Schematic diagram of MC55i sample application	96

0 Document History

New document: "MC55i Hardware Interface Description" Version **01.200a**

Preceding document: "MC55i Hardware Interface Description" Version 01.200

Chapter	What is new
5.5	Corrected CCIN input level at 1.8V supply.

New document: "MC55i Hardware Interface Description" Version 01.200

Preceding document: "MC55i Hardware Interface Description" Version 01.003

Chapter	What is new
3.3.1.2	Added remark regarding ignition line.
3.3.3.3	Removed all information related to NTC.
--	Deleted section "Undervoltage Shutdown if no Battery NTC is Present".
5.5	Revised $V_{I,min}$ value for charge interfaces' POWER signal. Added remark regarding required capacitor for POWER line (see also Figure 40). Revised $V_{IL,max}$ and $V_{IL,min}$ values for IGT signal.
7.2	Shortened chapter.
8	Updated Figure 40 : Sample SIM interface connection.

New document: "MC55i Hardware Interface Description" Version 01.003

Preceding document: "MC55i Hardware Interface Description" Version 00.310

Chapter	What is new
2.1	Updated key feature list.
3.3.1.1	Corrected description of power-up process.
3.5.2	Added further details on parameter <current> of AT^SBC.
3.5.3	Updated battery specifications in Table 10 .
3.5.5	Removed 60 minutes trickle charge timer.
3.5.6	Added AT^SMSO to list of AT commands supported in Charge-only mode.
3.5.7	Updated charger requirements.
3.5.8	New section: Switch off during Charge-only Mode .
5.1	Revised maximum rating for V_{BATT+}
5.7.3	Updated audio mode characteristics.
5.9	Updated ESD for antenna port.
6.1	Specified position of pins on board-to-board connector.
8	Updated Figure 40 to include external switch-off circuit and an updated capacitor value for half-wave charger.
9	New section: Mounting Advice Sheet .

New document: "MC55i Hardware Interface Description" Version 00.310

Chapter	What is new
	Initial document setup.

1 Introduction

This document¹ describes the hardware of the MC55i module that connects to the cellular device application and the air interface. It helps you quickly retrieve interface specifications, electrical and mechanical details and information on the requirements to be considered for integrating further components.

1.1 Related documents

- [1] MC55i AT Command Set
- [2] MC55i Release Notes
- [3] DSB45 Support Box - Evaluation Kit for Cinterion Wireless Module
- [4] Application Note 23: Installing MC55i on DSB45
- [5] Application Note 02: Audio Interface Design
- [6] Application Note 07: Li-Ion Batteries in GSM Applications
- [7] Application Note 16: Upgrading MC55i Firmware
- [8] Application Note 22: Using TTY / CTM equipment
- [9] Application Note 24: Application Developer's Guide
- [10] Multiplexer User's Guide
- [11] Multiplexer Driver Developer's Guide
- [12] Multiplexer Driver Installation Guide

Prior to using the MC55i modules or upgrading to a new firmware release, please carefully read the latest product information.

For further information visit the Cinterion Wireless Modules Website:
<http://www.cinterion.com>

¹ The document is effective only if listed in the appropriate Release Notes as part of the technical documentation delivered with your Cinterion Wireless Modules product.

1.2 Terms and Abbreviations

Abbreviation	Description
ADC	Analog-to-Digital Converter
AFC	Automatic Frequency Control
AGC	Automatic Gain Control
ANSI	American National Standards Institute
ARFCN	Absolute Radio Frequency Channel Number
ARP	Antenna Reference Point
ASC0 / ASC1	Asynchronous Serial Controller. Abbreviations used for first and second serial interface of MC55i
ASIC	Application Specific Integrated Circuit
B	Thermistor Constant
B2B	Board-to-board connector
BER	Bit Error Rate
BTS	Base Transceiver Station
CB or CBM	Cell Broadcast Message
CE	Conformité Européene (European Conformity)
CHAP	Challenge Handshake Authentication Protocol
CPU	Central Processing Unit
CS	Coding Scheme
CSD	Circuit Switched Data
CTS	Clear to Send
DAC	Digital-to-Analog Converter
DAI	Digital Audio Interface
dBm0	Digital level, 3.14dBm0 corresponds to full scale, see ITU G.711, A-law
DCE	Data Communication Equipment (typically modems, e.g. GSM module)
DCS 1800	Digital Cellular System, also referred to as PCN
DRX	Discontinuous Reception
DSB	Development Support Box
DSP	Digital Signal Processor
DSR	Data Set Ready
DTE	Data Terminal Equipment (typically computer, terminal, printer or, for example, GSM application)
DTR	Data Terminal Ready
DTX	Discontinuous Transmission
EFR	Enhanced Full Rate
EGSM	Enhanced GSM

Abbreviation	Description
EMC	Electromagnetic Compatibility
ESD	Electrostatic Discharge
ETS	European Telecommunication Standard
FCC	Federal Communications Commission (U.S.)
FDMA	Frequency Division Multiple Access
FR	Full Rate
GMSK	Gaussian Minimum Shift Keying
GPRS	General Packet Radio Service
GSM	Global Standard for Mobile Communications
HiZ	High Impedance
HR	Half Rate
I/O	Input/Output
IC	Integrated Circuit
IMEI	International Mobile Equipment Identity
ISO	International Standards Organization
ITU	International Telecommunications Union
kbps	kbits per second
LED	Light Emitting Diode
Li-Ion	Lithium-Ion
Mbps	Mbits per second
MMI	Man Machine Interface
MO	Mobile Originated
MS	Mobile Station (GSM module), also referred to as TE
MSISDN	Mobile Station International ISDN number
MT	Mobile Terminated
NTC	Negative Temperature Coefficient
OEM	Original Equipment Manufacturer
PA	Power Amplifier
PAP	Password Authentication Protocol
PBCCH	Packet Switched Broadcast Control Channel
PCB	Printed Circuit Board
PCL	Power Control Level
PCM	Pulse Code Modulation
PCN	Personal Communications Network, also referred to as DCS 1800
PCS	Personal Communication System, also referred to as GSM 1900
PDU	Protocol Data Unit

Abbreviation	Description
PLL	Phase Locked Loop
PPP	Point-to-point protocol
PSU	Power Supply Unit
R&TTE	Radio and Telecommunication Terminal Equipment
RAM	Random Access Memory
RF	Radio Frequency
RMS	Root Mean Square (value)
ROM	Read-only Memory
RTC	Real Time Clock
Rx	Receive Direction
SAR	Specific Absorption Rate
SELV	Safety Extra Low Voltage
SIM	Subscriber Identification Module
SMS	Short Message Service
SRAM	Static Random Access Memory
TA	Terminal adapter (e.g. GSM module)
TDMA	Time Division Multiple Access
TE	Terminal Equipment, also referred to as DTE
Tx	Transmit Direction
UART	Universal asynchronous receiver-transmitter
URC	Unsolicited Result Code
USSD	Unstructured Supplementary Service Data
VSWR	Voltage Standing Wave Ratio
<i>Phonebook abbreviations</i>	
FD	SIM fixdialing phonebook
LD	SIM last dialling phonebook (list of numbers most recently dialled)
MC	Mobile Equipment list of unanswered MT calls (missed calls)
ME	Mobile Equipment phonebook
ON	Own numbers (MSISDNs) stored on SIM or ME
RC	Mobile Equipment list of received calls
SM	SIM phonebook

1.3 Regulatory and Type Approval Information

1.3.1 Directives and Standards

MC55i has been designed to comply with the directives and standards listed below. It is the responsibility of the application manufacturer to ensure compliance of the final product with all provisions of the applicable directives and standards as well as with the technical specifications provided in the "MC55i Hardware Interface Description".²

Table 1: Directives

99/05/EC	Directive of the European Parliament and of the council of 9 March 1999 on radio equipment and telecommunications terminal equipment and the mutual recognition of their conformity (in short referred to as R&TTE Directive 1999/5/EC). The product is labeled with the CE conformity mark CE 0682
2002/95/EC	Directive of the European Parliament and of the Council of 27 January 2003 on the restriction of the use of certain hazardous substances in electrical and electronic equipment (RoHS) 

Table 2: Standards of North American type approval

CFR Title 47	Code of Federal Regulations, Part 22 and Part 24 (Telecommunications, PCS); US Equipment Authorization FCC
UL 60 950	Product Safety Certification (Safety requirements) 
NAPRD.03 V4.1	Overview of PCS Type certification review board Mobile Equipment Type Certification and IMEI control PCS Type Certification Review board (PTCRB)
RSS133 (Issue2)	Canadian Standard

Table 3: Standards of European type approval

3GPP TS 51.010-1	Digital cellular telecommunications system (Phase 2); Mobile Station (MS) conformance specification
ETSI EN 301 511 V9.0.2	Candidate Harmonized European Standard (Telecommunications series) Global System for Mobile communications (GSM); Harmonized standard for mobile stations in the GSM 900 and DCS 1800 bands covering essential requirements under article 3.2 of the R&TTE directive (1999/5/EC) (GSM 13.11 version 7.0.1 Release 1998)
GCF-CC V3.27.1	Global Certification Forum - Certification Criteria
ETSI EN 301 489-1 V1.4.1	Candidate Harmonized European Standard (Telecommunications series) Electro Magnetic Compatibility and Radio spectrum Matters (ERM); Electro Magnetic Compatibility (EMC) standard for radio equipment and services; Part 1: Common Technical Requirements

² Manufacturers of applications which can be used in the US shall ensure that their applications have a PTCRB approval. For this purpose they can refer to the PTCRB approval of the respective module.

Table 3: Standards of European type approval

ETSI EN 301 489-07 V1.2.1 (2000-09)	Candidate Harmonized European Standard (Telecommunications series) Electro Magnetic Compatibility and Radio spectrum Matters (ERM); Electro Magnetic Compatibility (EMC) standard for radio equipment and services; Part 7: Specific conditions for mobile and portable radio and ancillary equipment of digital cellular radio telecommunications systems (GSM and DCS)
EN 60950-1 (2001)	Safety of information technology equipment

Table 4: Requirements of quality

IEC 60068	Environmental testing
DIN EN 60529	IP codes

Table 5: Standards of the Ministry of Information Industry of the People’s Republic of China

SJ/T 11363-2006	“Requirements for Concentration Limits for Certain Hazardous Substances in Electronic Information Products” (2006-06).
SJ/T 11364-2006	<p>“Marking for Control of Pollution Caused by Electronic Information Products” (2006-06).</p> <p>According to the “Chinese Administration on the Control of Pollution caused by Electronic Information Products” (ACPEIP) the EPUP, i.e., Environmental Protection Use Period, of this product is 20 years as per the symbol shown here, unless otherwise marked. The EPUP is valid only as long as the product is operated within the operating limits described in the Cinterion Wireless Modules Hardware Interface Description.</p> <p>Please see Table 6 for an overview of toxic or hazardous substances or elements that might be contained in product parts in concentrations above the limits defined by SJ/T 11363-2006.</p> 

Table 6: Toxic or hazardous substances or elements with defined concentration limits

部件名称 Name of the part	有毒有害物质或元素 Hazardous substances					
	铅 (Pb)	汞 (Hg)	镉 (Cd)	六价铬 (Cr(VI))	多溴联苯 (PBB)	多溴二苯醚 (PBDE)
金属部件 (Metal Parts)	○	○	○	○	○	○
电路模块 (Circuit Modules)	X	○	○	○	○	○
电缆及电缆组件 (Cables and Cable Assemblies)	○	○	○	○	○	○
塑料和聚合物部件 (Plastic and Polymeric parts)	○	○	○	○	○	○

O:
表示该有毒有害物质在该部件所有均质材料中的含量均在SJ/T11363-2006 标准规定的限量要求以下。
Indicates that this toxic or hazardous substance contained in all of the homogeneous materials for this part is below the limit requirement in SJ/T11363-2006.

X:
表示该有毒有害物质至少在该部件的某一均质材料中的含量超出SJ/T11363-2006标准规定的限量要求。
Indicates that this toxic or hazardous substance contained in at least one of the homogeneous materials used for this part *might exceed* the limit requirement in SJ/T11363-2006.

1.3.2 SAR Requirements Specific to Portable Mobiles

Mobile phones, PDAs or other portable transmitters and receivers incorporating a GSM module must be in accordance with the guidelines for human exposure to radio frequency energy. This requires the Specific Absorption Rate (SAR) of portable MC55i based applications to be evaluated and approved for compliance with national and/or international regulations.

Since the SAR value varies significantly with the individual product design manufacturers are advised to submit their product for approval if designed for portable use. For European and US markets the relevant directives are mentioned below. It is the responsibility of the manufacturer of the final product to verify whether or not further standards, recommendations or directives are in force outside these areas.

Products intended for sale on US markets







ES 59005/ANSI C95.1 Considerations for evaluation of human exposure to Electro-magnetic Fields (EMFs) from Mobile Telecommunication Equipment (MTE) in the frequency range 30MHz - 6GHz

Products intended for sale on European markets

EN 50360: Product standard to demonstrate the compliance of mobile phones with the basic restrictions related to human exposure to electro-magnetic fields (300MHz - 3GHz)

1.3.3 Safety Precautions

The following safety precautions must be observed during all phases of the operation, usage, service or repair of any cellular terminal or mobile incorporating MC55i. Manufacturers of the cellular terminal are advised to convey the following safety information to users and operating personnel and to incorporate these guidelines into all manuals supplied with the product. Failure to comply with these precautions violates safety standards of design, manufacture and intended use of the product. Cinterion Wireless Modules GmbH assumes no liability for customer failure to comply with these precautions.

	<p>When in a hospital or other health care facility, observe the restrictions on the use of mobiles. Switch the cellular terminal or mobile off, if instructed to do so by the guidelines posted in sensitive areas. Medical equipment may be sensitive to RF energy.</p> <p>The operation of cardiac pacemakers, other implanted medical equipment and hearing aids can be affected by interference from cellular terminals or mobiles placed close to the device. If in doubt about potential danger, contact the physician or the manufacturer of the device to verify that the equipment is properly shielded. Pacemaker patients are advised to keep their hand-held mobile away from the pacemaker, while it is on.</p>
	<p>Switch off the cellular terminal or mobile before boarding an aircraft. Make sure it cannot be switched on inadvertently. The operation of wireless appliances in an aircraft is forbidden to prevent interference with communications systems. Failure to observe these instructions may lead to the suspension or denial of cellular services to the offender, legal action, or both.</p>
	<p>Do not operate the cellular terminal or mobile in the presence of flammable gases or fumes. Switch off the cellular terminal when you are near petrol stations, fuel depots, chemical plants or where blasting operations are in progress. Operation of any electrical equipment in potentially explosive atmospheres can constitute a safety hazard.</p>
	<p>Your cellular terminal or mobile receives and transmits radio frequency energy while switched on. Remember that interference can occur if it is used close to TV sets, radios, computers or inadequately shielded equipment. Follow any special regulations and always switch off the cellular terminal or mobile wherever forbidden, or when you suspect that it may cause interference or danger.</p>
	<p>Road safety comes first! Do not use a hand-held cellular terminal or mobile when driving a vehicle, unless it is securely mounted in a holder for handsfree operation. Before making a call with a hand-held terminal or mobile, park the vehicle.</p> <p>Handsfree devices must be installed by qualified personnel. Faulty installation or operation can constitute a safety hazard.</p>
	<p>IMPORTANT!</p> <p>Cellular terminals or mobiles operate using radio signals and cellular networks. Because of this, connection cannot be guaranteed at all times under all conditions. Therefore, you should never rely solely upon any wireless device for essential communications, for example emergency calls.</p> <p>Remember, in order to make or receive calls, the cellular terminal or mobile must be switched on and in a service area with adequate cellular signal strength.</p> <p>Some networks do not allow for emergency calls if certain network services or phone features are in use (e.g. lock functions, fixed dialling etc.). You may need to deactivate those features before you can make an emergency call.</p> <p>Some networks require that a valid SIM card be properly inserted in the cellular terminal or mobile.</p>

2 Product Concept

2.1 MC55i Key Features at a Glance

Feature	Implementation
<i>General</i>	
Frequency bands	Quad band: GSM 850/900/1800/1900MHz
GSM class	Small MS
Output power (according to Release 99, V5)	Class 4 (+33dBm ±2dB) for EGSM850 Class 4 (+33dBm ±2dB) for EGSM900 Class 1 (+30dBm ±2dB) for GSM1800 Class 1 (+30dBm ±2dB) for GSM1900
Power supply	$3.3V \leq V_{BATT+} \leq 4.8V$
Ambient operating temperature according to IEC 60068-2	Normal operation: -20°C to +55°C Restricted operation: -40°C to -20°C and +55°C to +70°C
Physical	Dimensions: 32.5mm x 35mm x max. 3.1mm Weight: approx. 6g
RoHS	All hardware components fully compliant with EU RoHS Directive
<i>GSM / GPRS features</i>	
Data transfer	GPRS: <ul style="list-style-type: none"> • Multislot Class 10 • Full PBCCH support • Mobile Station Class B • Coding Scheme 1 – 4 CSD: <ul style="list-style-type: none"> • V.110, RLP, non-transparent • 2.4, 4.8, 9.6, 14.4kbps • USSD PPP-stack for GPRS data transfer
SMS	Point-to-point MT and MO Cell broadcast Text and PDU mode Storage: SIM card plus 25 SMS locations in mobile equipment Transmission of SMS alternatively over CSD or GPRS. Preferred mode can be user defined.
Fax	Group 3; Class 2 and Class 1
Audio	Speech codecs: <ul style="list-style-type: none"> • Half Rate (ETS 06.20) • Full Rate (ETS 06.10) • Enhanced Full Rate (ETS 06.50 / 06.60 / 06.80) • Adaptive Multi Rate AMR Handsfree operation, echo cancellation, noise reduction, 7 different ringing tones / melodies

Feature	Implementation
<i>Software</i>	
AT commands	Hayes 3GPP TS 27.007, TS 27.005, Cinterion Wireless Modules AT commands for RIL compatibility
SIM Application Toolkit	Supports SAT class 3, GSM 11.14 Release 98, support of letter class "c"
Firmware update	Windows executable for update over serial interface ASC0
<i>Interfaces</i>	
2 serial interfaces	<p>ASC0:</p> <ul style="list-style-type: none"> 8-wire modem interface with status and control lines, unbalanced, asynchronous Fixed bit rates: 300bps to 230,000bps Autobauding: 1,200bps to 230,000bps Supports RTS0/CTS0 hardware handshake and software XON/XOFF flow control. Multiplex ability according to GSM 07.10 Multiplexer Protocol. <p>ASC1:</p> <ul style="list-style-type: none"> 4-wire, unbalanced asynchronous interface Fixed bit rates: 300bps to 230,000bps Supports RTS1/CTS1 hardware handshake and software XON/XOFF flow control
Audio	2 analog interfaces 1 digital interface (DAI)
SIM interface	Supported SIM cards: 3V, 1.8V External SIM card reader has to be connected via interface connector (note that card reader is not part of MC55i)
Antenna	50Ω. External antenna can be connected via antenna connector or solderable pad.
Module interface	50-pin board-to-board connector
<i>Power on/off, Reset</i>	
Power on/off	Switch-on by hardware pin IGT Switch-off by AT command (AT^SMSO) Automatic switch-off in case of critical temperature and voltage conditions
Reset	Orderly shutdown and reset by AT command
<i>Special features</i>	
Charging	Supports management of rechargeable Lithium Ion and Lithium Polymer batteries.
Real time clock	Timer functions via AT commands
Phonebook	SIM and phone
TTY/CTM support	Integrated CTM modem
<i>Evaluation kit</i>	
DSB45	DSB45 Evaluation board designed to test and type approve Cinterion Wireless Module and provide a sample configuration for application engineering.

2.2 MC55i System Overview

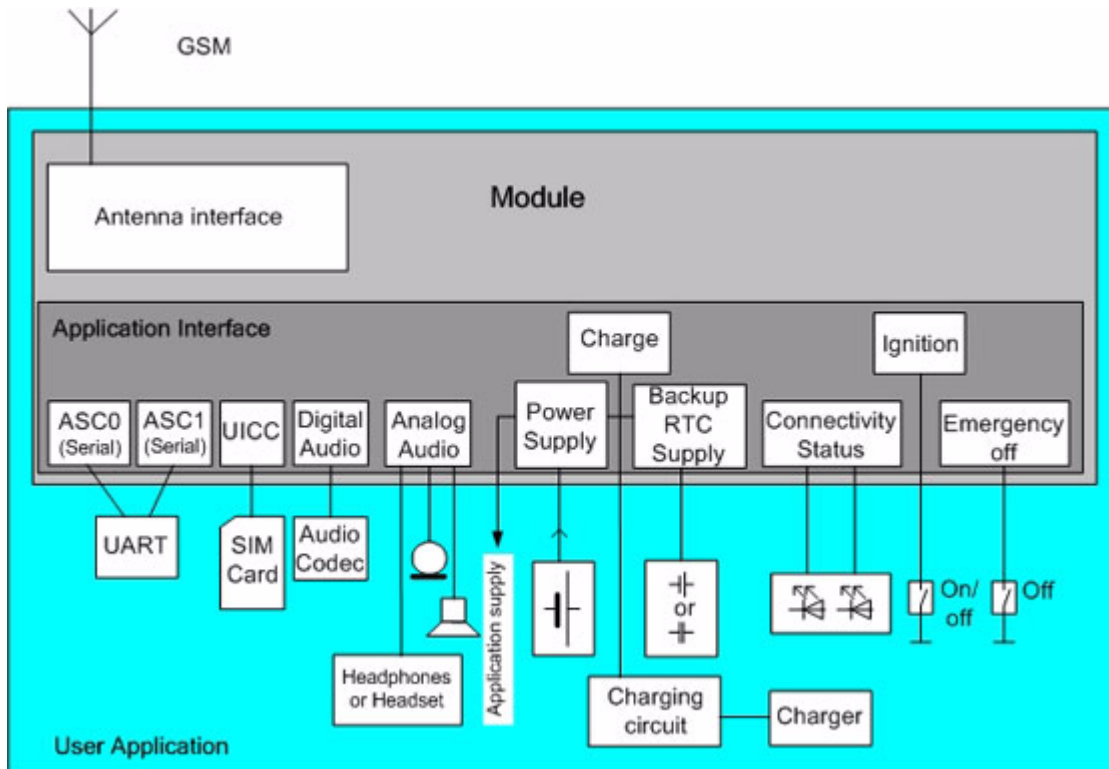

Figure 1: MC55i system overview

2.3 Circuit Concept

Figure 2 shows a block diagram of the MC55i module and illustrates the major functional components:

The baseband consists of the following parts:

- GSM baseband processor
- Power Supply (ASIC)
- Stacked flash / SRAM memory

GSM RF block:

- RF transceiver
- 26MHz reference clock oscillator
- Power amplifier / front-end module inc. harmonics filtering
- Receive SAW filters

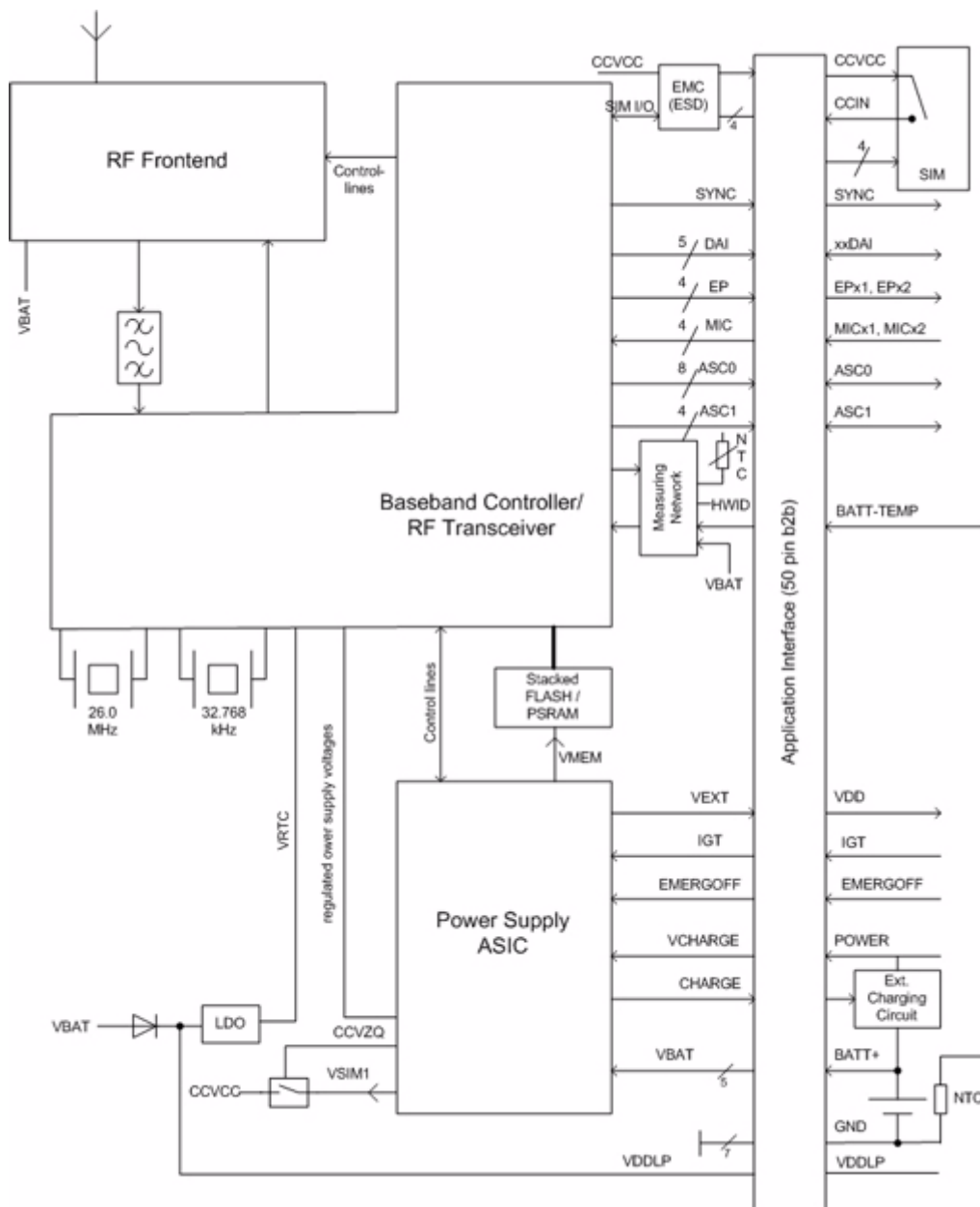

Figure 2: MC55i block diagram

3 Application Interface

MC55i is equipped with a 50-pin 0.5 mm pitch board-to-board connector that connects to the external application. The host interface incorporates several sub-interfaces described in the following sections:

- Power supply - see [Section 3.2](#)
- Charger interface - see [Section 3.5](#)
- Serial interface ASC0 - see [Section 3.9](#)
- Serial interface ASC1 - see [Section 3.10](#)
- Two analog audio interfaces - see [Section 3.11](#)
- Digital audio interface (DAI) - see [Section 3.11](#)
- SIM interface - see [Section 3.12](#)
- Status and control lines: IGT, EMERG_RST, PWR_IND, SYNC - see [Table 32](#)

Electrical and mechanical characteristics of the board-to-board connector are specified in [Section 6.3](#). Ordering information for mating connectors and cables are included.

3.1 Operating Modes

The table below briefly summarizes the various operating modes referred to in the following sections.

Table 7: Overview of operating modes

Mode	Function
Normal operation	GSM / GPRS SLEEP Various powersave modes set with AT+CFUN command. Software is active to minimum extent. If the module was registered to the GSM network in IDLE mode, it is registered and paging with the BTS in SLEEP mode, too. Power saving can be chosen at different levels: The NON-CYCLIC SLEEP mode (AT+CFUN=0) disables the AT interface. The CYCLIC SLEEP modes AT+CFUN=5, 6, 7, 8 and 9 alternately activate and deactivate the AT interfaces to allow permanent access to all AT commands.
	GSM IDLE Software is active. Once registered to the GSM network, paging with BTS is carried out. The module is ready to send and receive.
	GSM TALK Connection between two subscribers is in progress. Power consumption depends on network coverage individual settings, such as DTX off/on, FR/EFR/HR, hopping sequences, antenna.
	GPRS IDLE Module is ready for GPRS data transfer, but no data is currently sent or received. Power consumption depends on network settings and GPRS configuration (e.g. multislot settings).
	GPRS DATA GPRS data transfer in progress. Power consumption depends on network settings (e.g. power control level), uplink / downlink data rates and GPRS configuration (e.g. used multislot settings).
POWER DOWN	Normal shutdown after sending the AT^SMSO command. Only a voltage regulator is active for powering the RTC. Software is not active. Interfaces are not accessible. Operating voltage (connected to BATT+) remains applied. Please note that during charging, i.e., as long as a charger is connected, it is not possible to shut down the module and reach POWER DOWN mode. This applies to normal, automatic and EMERGOFF triggered shutdowns.
Alarm mode	Restricted operation launched by RTC alert function while the module is in POWER DOWN mode. Module will not be registered to GSM network. Limited number of AT commands is accessible.
Charge-only mode	Limited operation for battery powered applications. Enables charging while module is detached from GSM network. Limited number of AT commands is accessible. There are several ways to launch Charge-only mode: <ul style="list-style-type: none"> From POWER DOWN mode: Connect charger to the charger input pin of the external charging circuit and the module's POWER pin when MC55i was powered down by AT^SMSO. From Normal mode: Connect charger to the charger input pin of the external charging circuit and the module's POWER pin, then enter AT^SMSO.
Charge mode during normal operation	Normal operation (SLEEP, IDLE, TALK, GPRS IDLE, GPRS DATA) and charging running in parallel. Charge mode changes to Charge-only mode when the module is powered down before charging has been completed.

See [Table 13](#) and [Table 14](#) for the various options of waking up MC55i and proceeding from one mode to another.

3.2 Power Supply

MC55i needs to be connected to a power supply at the board-to-board connector (5 pins each BATT+ and GND).

The power supply of MC55i has to be a single voltage source at BATT+. It must be able to provide the peak current during the uplink transmission.

All the key functions for supplying power to the device are handled by an ASIC power supply. The ASIC provides the following features:

- Stabilizes the supply voltages for the GSM baseband using low drop linear voltage regulators.
- Switches the module's power voltages for the power-up and -down procedures.
- Delivers, across the VDD pin, a regulated voltage for an external application. This voltage is not available in Power-down mode.
- SIM switch to provide SIM power supply.

3.2.1 Minimizing Power Losses

When designing the power supply for your application please pay specific attention to power losses. Ensure that the input voltage $V_{\text{BATT+}}$ never drops below 3.3V on the MC55i board, not even in a transmit burst where current consumption can rise to typical peaks of 1.6A. It should be noted that MC55i switches off when exceeding these limits. Any voltage drops that may occur in a transmit burst should not exceed 400mV. For further details see [Section 5.6](#).

The measurement network monitors outburst and inburst values. The drop is the difference of both values. The maximum drop (D_{max}) since the last start of the module will be saved. In IDLE and SLEEP mode, the module switches off if the minimum battery voltage (V_{battmin}) is reached.

Example:

$V_{\text{Imin}} = 3.3\text{V}$

$D_{\text{max}} = 0.4\text{V}$

$V_{\text{battmin}} = V_{\text{Imin}} + D_{\text{max}}$

$V_{\text{battmin}} = 3.3\text{V} + 0.4\text{V} = 3.7\text{V}$

The best approach to reducing voltage drops is to use a board-to-board connection as recommended, and a low impedance power source. The resistance of the power supply lines on the host board and of a battery pack should also be considered.

Note: If the application design requires an adapter cable between both board-to-board connectors, use a cable as short as possible in order to minimize power losses.

Example: If the length of the cable reaches the maximum length of 200mm, this connection may cause, for example, a resistance of 50mΩ in the BATT+ line and 50mΩ in the GND line. As a result, a 1.6A transmit burst would add up to a total voltage drop of 160mV. Plus, if a battery pack is involved, further losses may occur due to the resistance across the battery lines and the internal resistance of the battery including its protective circuit.

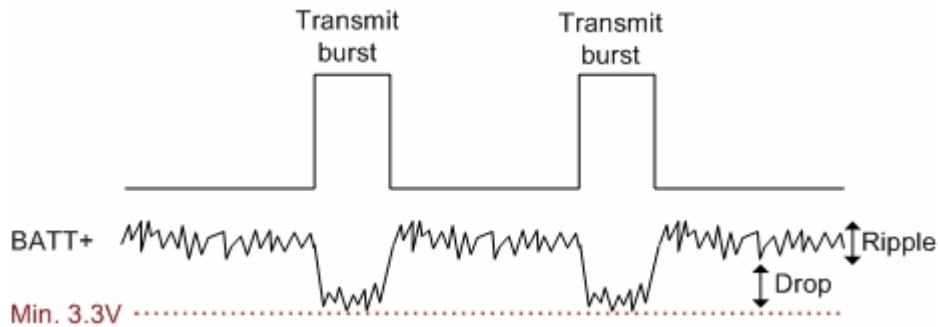

Figure 3: Power supply limits during transmit burst

3.2.2 Measuring the Supply Voltage (V_{BATT+})

Figure 4 shows reference test points for measuring the supply voltage V_{BATT+} on the module: TP BATT+ and TP GND. Both test points are accessible close to the board-to-board connector of the module.

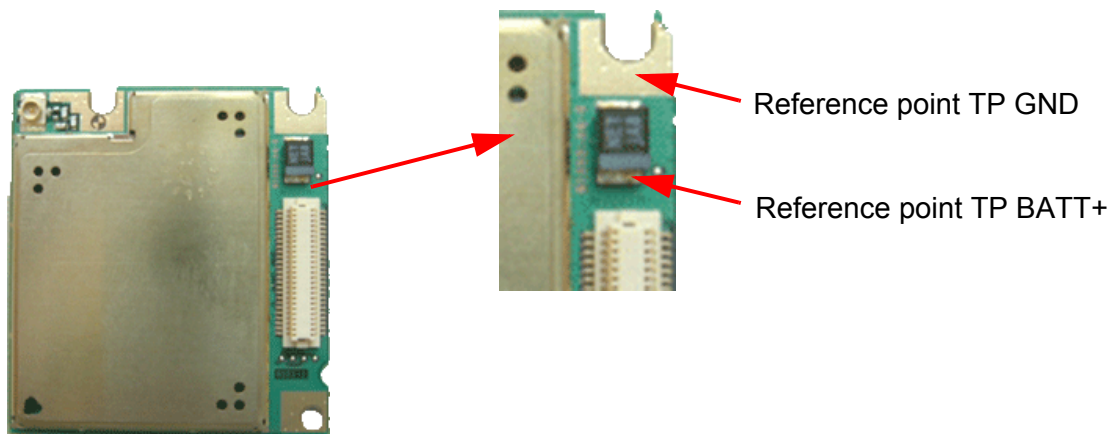

Figure 4: Position of the reference test points TP BATT+ and TP GND

3.2.3 Monitoring Power Supply

To help you monitor the supply voltage you can use the AT^SBV command which returns the voltage related to the test points TP BATT+ and TP GND.

The voltage is continuously measured at intervals depending on the operating mode on the RF interface. The duration of measuring ranges from 0.5s in TALK/DATA mode up to 50s when MC55i is in IDLE mode or Limited Service (deregistered). The displayed voltage (in mV) is averaged over the last measuring period before the AT^SBV command was executed.

3.3 Power Up / Power Down Scenarios

In general, be sure not to turn on MC55i while it is out of the operating range of voltage and temperature stated in [Section 5.2](#) and [Section 5.6](#). MC55i would immediately switch off after having started and detected these inappropriate conditions.

3.3.1 Turn on MC55i

MC55i can be started in a variety of ways as described in the following sections:

- Hardware driven startup by IGT line: Starts Normal mode (see [Section 3.3.1.1](#) and [Section 3.3.1.2](#)).
- Software controlled reset by AT+CFUN command: starts Normal mode or Alarm mode.
- Hardware driven start-up by VCHARGE line line: Starts charging algorithm (see [Section 3.3.1.3](#) and [Section 3.5.6](#)).
- Wake-up from Power-down mode by using RTC interrupt: Starts Alarm mode (see [Section 3.3.1.4](#)).

3.3.1.1 Turn on MC55i using the Ignition Line IGT (Power on)

To switch on MC55i the IGT (Ignition) signal needs to be driven to ground level for at least 100ms after BATT+ has reached 3.3V. This can be accomplished using an open drain/collector driver in order to avoid current flowing into this pin.

In a battery operated MC55i application, the duration of the IGT signal must be 1s minimum when the charger is connected and you may want to go from Charge only mode to Normal mode.

Assertion of CTS indicates that the module is ready to receive data from the host application. In addition, if configured to a fixed bit rate (AT+IPR≠0), the module will send the URC “^SYSSTART” which notifies the host application that the first AT command can be sent to the module. The duration until this URC is output varies with the SIM card and may take a couple of seconds, particularly if the request for the SIM PIN is deactivated on the SIM card.

Please note that no “^SYSSTART” URC will be generated if autobauding (AT+IPR=0) is enabled.

To allow the application to detect the ready state of the module we recommend using hardware flow control which can be set with AT\Q (see [\[1\]](#) for details). The default setting of MC55i is AT\Q0 (no flow control) which shall be altered to AT\Q3 (RTS/CTS handshake). If the application design does not integrate RTS/CTS lines the host application shall wait at least for the “^SYSSTART” URC. However, if the URCs are neither used (due to autobauding) then the only way of checking the module’s ready state is polling. To do so, try to send characters (e.g. “at”) until the module is responding.

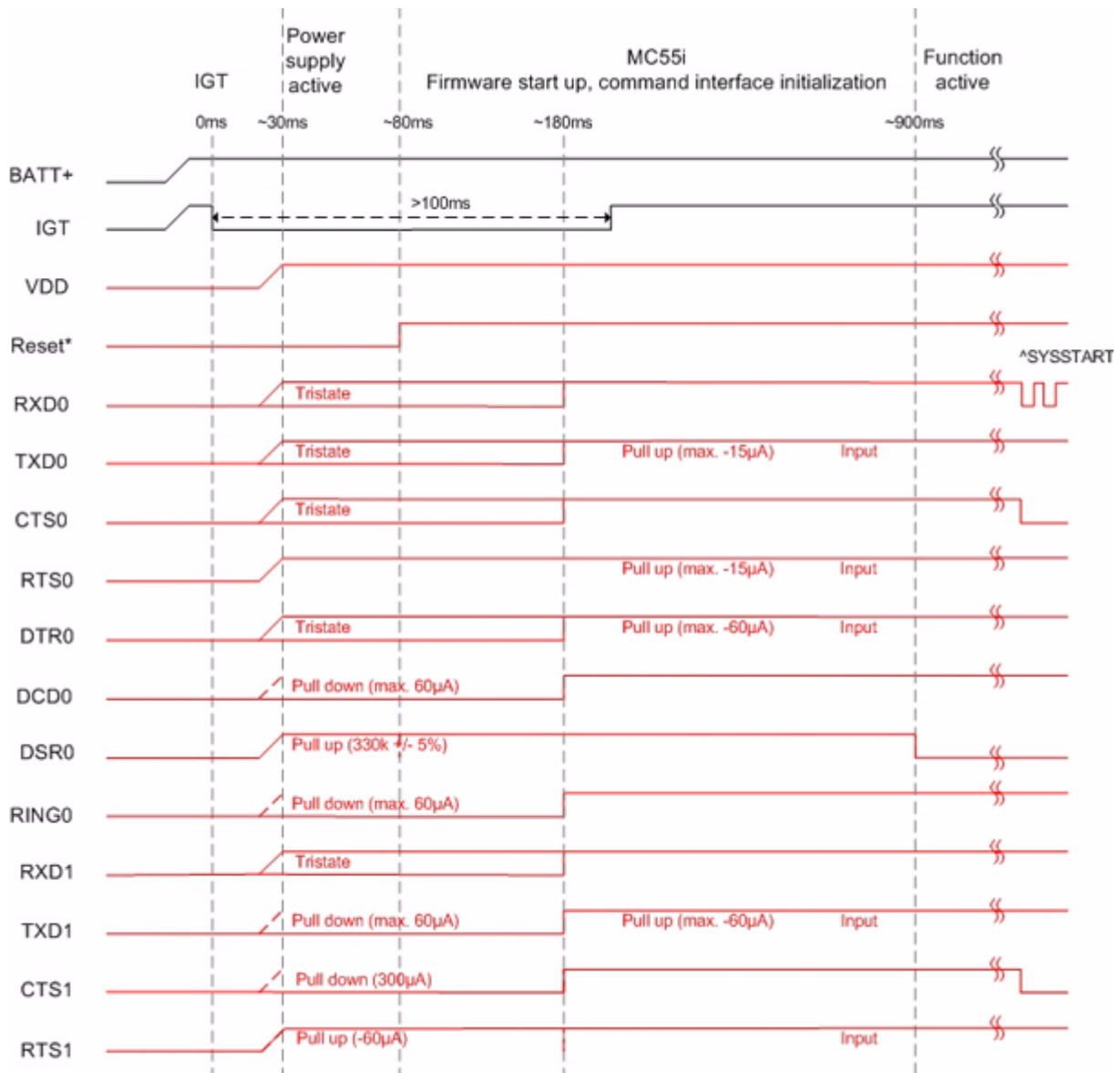

* Reset is an internal signal that is set to high once the module's processor is powered up.

Figure 5: Power-on by ignition signal

3.3.1.2 Timing of the Ignition Process

When designing your application platform take into account that powering up MC55i requires the following steps.

- The ignition line cannot be operated until V_{BATT+} passes the level of 3.3V.
- 100ms are required to power up the module.
- Ensure that V_{BATT+} does not fall below 3.3V while the ignition line is driven. Otherwise the module cannot be activated.

Note: If the IGT line remains low after power up, the module cannot be switched off using the command AT^SMSO or the EMERG_OFF line. Instead the module will automatically restart.

3.3.1.3 Turn on MC55i using the POWER Signal

As detailed in [Section 3.5.6](#), the charging adapter can be connected regardless of the module's operating mode.

If the charger is connected to the charger input of the external charging circuit and the module's POWER pin while MC55i is off, processor controlled fast charging starts (see [Section 3.5.5](#)). MC55i enters a restricted mode, referred to as Charge-only mode where only the charging algorithm will be launched.

During the Charge-only mode MC55i is neither logged on to the GSM network nor are the serial interfaces fully accessible. To switch to normal operation and log on to the GSM network, the IGT line needs to be activated.

3.3.1.4 Turn on MC55i using the RTC (Alarm Mode)

Another power-on approach is to use the RTC, which is constantly supplied with power from a separate voltage regulator in the power supply ASIC. The RTC provides an alert function, which allows the MC55i to wake up whilst the internal voltage regulators are off. To prevent the module from unintentionally logging into the GSM network, this procedure only enables restricted operation, referred to as Alarm mode. It must not be confused with a wake-up or alarm call that can be activated by using the same AT command, but without switching off power.

Use the `AT+CALA` command to set the alarm time. The RTC retains the alarm time if MC55i was powered down by `AT^SMSO`. Once the alarm is timed out and executed, MC55i enters the Alarm mode. This is indicated by an Unsolicited Result Code (URC) which reads:

```
^SYSSTART ALARM MODE
```

Note that this URC is the only indication of the Alarm mode and will not appear when autobauding was activated (due to the missing synchronization between DTE and DCE upon start-up). Therefore, it is recommended to select a fixed baudrate before using the Alarm mode.

In Alarm mode only a limited number of AT commands is available. For further instructions refer to the AT Command Set.

Table 8: AT commands available in Alarm mode

AT command	Use
AT+CALA	Set alarm time
AT+CCLK	Set date and time of RTC
AT^SBC	In Alarm mode, you can only query the present current consumption and check whether or not a charger is connected. The battery capacity is returned as 0, regardless of the actual voltage (since the values measured directly on the cell are not delivered to the module).
AT^SCTM	Query temperature range, enable/disable URCs to report critical temperature ranges
AT^SMSO	Power down GSM module

For the GSM module to change from the Alarm mode to full operation (normal operating mode)

it is necessary to drive the ignition line to ground. This must be implemented in your host application as described in [Section 3.3.1.1](#).

If the charger is connected to the POWER line when MC55i is in ALARM mode charging will start, while MC55i stays in ALARM mode. See also [Section 3.7](#) which summarizes the various options of changing the mode of operation.

If your host application uses the SYNC pin to control a status LED as described in [Section 3.13.2.2](#), please note that the LED is off while the GSM module is in Alarm mode.

3.3.2 Turn off MC55i

To switch the module off the following procedures may be used:

- *Normal shutdown procedure:* Software controlled by sending the AT[^]SMSO command over the serial application interface. See [Section 3.3.2.1](#).
- *Emergency shutdown:* Hardware driven by switching the EMERGOFF line of the board-to-board-connector to ground = immediate shutdown of supply voltages, only applicable if the software controlled procedure fails. See [Section 3.3.2.2](#).
- *Automatic shutdown:* See [Section 3.3.3](#)
 - Takes effect if undervoltage is detected.
 - Takes effect if MC55i board temperature exceeds critical limit.

3.3.2.1 Turn off MC55i using AT Command

The best and safest approach to powering down MC55i is to issue the AT[^]SMSO command. This procedure lets MC55i log off from the network and allows the software to enter into a secure state and save data before disconnecting the power supply. The mode is referred to as POWER DOWN mode. In this mode, only the RTC stays active.

Before switching off the device sends the following response:

```
^SMSO: MS OFF
```

```
OK
^SHUTDOWN
```

After sending AT[^]SMSO do not enter any other AT commands. There are two ways to verify when the module turns off:

- Wait for the URC “^SHUTDOWN”. It indicates that data have been stored non-volatile and the module turns off in less than 1 second.
- Also, you can monitor the VDD pin. The low state of VDD definitely indicates that the module is switched off.

Be sure not to disconnect the operating voltage V_{BATT+} before the URC “^SHUTDOWN” has been issued and the VDD signal has gone low. Otherwise you run the risk of losing data.

While MC55i is in POWER DOWN mode the application interface is switched off and must not be fed from any other source. Therefore, your application must be designed to avoid any current flow into any digital pins of the application interface.

Note: In POWER DOWN mode, the EMERGOFF pin, the output pins of the ASC0 interface RXD0, CTS0, DCD0, DSR0, RING0 and the output pins of the ASC1 interface RXD1 and CTS1 are switched to high impedance state.

If this causes the associated input pins of your application to float, you are advised to integrate an additional resistor (100 k Ω – 1 M Ω) at each line. In the case of the serial interface pins you can either connect pull-up resistors to the VDD line, or pull-down resistors to GND.

3.3.2.2 Emergency Shutdown using EMERGOFF Pin

Caution: Use the EMERGOFF pin only when, due to serious problems, the software is not responding for more than 5 seconds. Pulling the EMERGOFF pin causes the loss of all information stored in the volatile memory since power is cut off immediately. Therefore, this procedure is intended only for use in case of emergency, e.g. if MC55i fails to shut down properly.

The EMERGOFF signal is available on the board-to-board connector. To control the EMERGOFF line it is recommended to use an open drain / collector driver. To turn the GSM module off, the EMERGOFF line has to be driven to ground for at least 10ms.

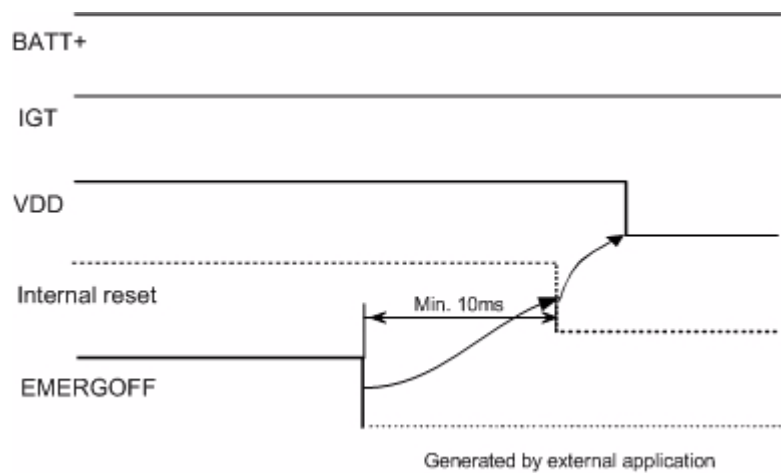

Figure 6: Deactivating GSM module by EMERGOFF signal

3.3.3 Automatic Shutdown

Automatic shutdown takes effect if

- the MC55i board is exceeding the critical limits of overtemperature or undertemperature
- the battery is exceeding the critical limits of overtemperature or undertemperature
- undervoltage is detected

The automatic shutdown procedure is equivalent to the power-down initiated with the AT^SM-SO command, i.e. MC55i logs off from the network and the software enters a secure state avoiding loss of data. *Note: This does not apply if overvoltage conditions or unrecoverable hardware or software errors occur (see below for details).*

Alert messages transmitted before the device switches off are implemented as Unsolicited Result Codes (URCs). The presentation of these URCs can be enabled or disabled with the two AT commands AT^SBC and AT^SCTM. The URC presentation mode varies with the condition, please see [Section 3.3.3.1](#) to [Section 3.3.3.3](#) for details. For further instructions on AT commands refer to [\[1\]](#).

3.3.3.1 Thermal Shutdown

The board temperature is constantly monitored by an internal NTC resistor located on the PCB. The NTC that detects the battery temperature must be part of the battery pack circuit as described in [Section 3.5.3](#). The values detected by either NTC resistor are measured directly on the board or the battery and therefore, are not fully identical with the ambient temperature.

Each time the board or battery temperature goes out of range or back to normal, MC55i instantly displays an alert (if enabled).

- URCs indicating the level "1" or "-1" allow the user to take appropriate precautions, such as protecting the module from exposure to extreme conditions. The presentation of the URCs depends on the settings selected with the AT^SCTM write command:
AT^SCTM=1: Presentation of URCs is always enabled.
AT^SCTM=0 (default): Presentation of URCs is enabled during the 2 minute guard period after start-up of MC55i. After expiry of the 2 minute guard period, the presentation will be disabled, i.e. no URCs with alert levels "1" or "-1" will be generated.
- URCs indicating the level "2" or "-2" are instantly followed by an orderly shutdown, except in cases described in [Section 3.3.3.2](#). The presentation of these URCs is always enabled, i.e. they will be output even though the factory setting AT^SCTM=0 was never changed.

The maximum temperature ratings are stated in [Section 5.2](#). Refer to [Table 9](#) for the associated URCs.

Table 9: Temperature dependent behavior

Sending temperature alert (2min after start-up, otherwise only if URC presentation enabled)	
^SCTM_A: 1	Battery close to overtemperature limit.
^SCTM_B: 1	Board close to overtemperature limit.
^SCTM_A: -1	Battery close to unde temperature limit.
^SCTM_B: -1	Board close to unde temperature limit.
^SCTM_A: 0	Battery back to non-critical temperature range.
^SCTM_B: 0	Board back to non-critical temperature range.
Automatic shutdown (URC appears no matter whether or not presentation was enabled)	
^SCTM_A: 2	Alert: Battery equal or beyond overtemperature limit. MC55i switches off.
^SCTM_B: 2	Alert: Board equal or beyond overtemperature limit. MC55i switches off.
^SCTM_A: -2	Alert: Battery equal or below undertemperature limit. MC55i switches off.
^SCTM_B: -2	Alert: Board equal or below undertemperature limit. MC55i switches off.

3.3.3.2 Deferred Shutdown at Extreme Temperature Conditions

In the following cases, automatic shutdown will be deferred if a critical temperature limit is exceeded:

- While an emergency call is in progress.
- During a two minute guard period after power-up. This guard period has been introduced in order to allow for the user to make an emergency call. The start of any one of these calls extends the guard period until the end of the call. Any other network activity may be terminated by shutdown upon expiry of the guard time.

While in a "deferred shutdown" situation, MC55i continues to measure the temperature and to deliver alert messages, but deactivates the shutdown functionality. Once the 2 minute guard period is expired or the call is terminated, full temperature control will be resumed. If the temperature is still out of range, MC55i switches off immediately (without another alert message).

CAUTION! Automatic shutdown is a safety feature intended to prevent damage to the module. Extended usage of the deferred shutdown facilities provided may result in damage to the module, and possibly other severe consequences.

3.3.3.3 Undervoltage Shutdown

If the measured battery voltage is no more sufficient to set up a call the following URC will be presented:

^SBC: Undervoltage.

The message will be reported, for example, when you attempt to make a call while the voltage is close to the critical limit and further power loss is caused during the transmit burst. To remind you that the battery needs to be charged soon, the URC appears several times before the module switches off.

To enable or disable the URC use the AT^SBC command. The URC will be enabled when you enter the write command and specify the power consumption of your GSM application. Step by step instructions are provided in [\[1\]](#).

3.3.3.4 Overvoltage Shutdown

For overvoltage conditions, no software controlled shutdown is implemented. If the supply voltage exceeds the maximum value specified in [Table 33](#), loss of data and even unrecoverable hardware damage can occur.

Keep in mind that several MC55i components are directly linked to BATT+ and, therefore, the supply voltage remains applied at major parts of MC55i. Especially the power amplifier is very sensitive to high voltage and might even be destroyed.

3.4 Automatic GPRS Multislot Class Change

Temperature control is also effective for operation in GPRS Multislot Class 10. If the board temperature increases to the limit specified for restricted operation (see [Section 5.2](#) for temperature limits) while data is transmitted over GPRS, the module automatically reverts from GPRS Multislot Class 10 (2Tx) to Class 8 (1Tx). This reduces the power consumption and, consequently, causes the board's temperature to decrease. Once the temperature drops to a value of 5 degrees below the limit of restricted operation, MC55i returns to the higher Multislot Class. If the temperature stays at the critical level or even continues to rise, MC55i will not switch back to the higher class.

After a transition from Multislot Class 10 to Multislot 8 a possible switchback to Multislot Class 10 is blocked for one minute.

Please note that there is not one single cause of switching over to a lower GPRS Multislot Class. Rather it is the result of an interaction of several factors, such as the board temperature that depends largely on the ambient temperature, the operating mode and the transmit power. Furthermore, take into account that there is a delay until the network proceeds to a lower or, accordingly, higher Multislot Class. The delay time is network dependent. In extreme cases, if it takes too much time for the network and the temperature cannot drop due to this delay, the module may even switch off as described in [Section 3.3.3.1](#).

3.5 Charging Control

MC55i integrates a charging management for rechargeable Lithium Ion and Lithium Polymer batteries. You can skip this chapter if charging is not your concern, or if you are not using the implemented charging algorithm.

The following sections contain an overview of charging and battery specifications. Please refer to [6] for greater detail, especially regarding requirements for batteries and chargers, appropriate charging circuits and an analysis of operational issues typical of battery powered GSM/GPRS applications.

3.5.1 Hardware Requirements

MC55i has no on-board charging circuit, but delivers, via its POWER line and CHARGE line, the control signals needed to start and stop the charging process. To benefit from the implemented charging management you are required to install a charging circuit within your application according to the Figure 40.

3.5.2 Software Requirements

Use the AT^SBC command, parameter <current>, to enter the current consumption of the host application. If used, the current drawn from the VDD line shall be added, too.

This information enables the MC55i module to correctly determine the end of charging and terminate charging automatically when the battery is fully charged.

If the <current> value was not specified and no battery NTC is detected the AT^SBC command returns only the module's present current consumption.

If the <current> value was not specified, but the NTC of the connected battery is detected, an offset value of 200mA will be set by default. This value represents the assumed current consumption of a typical external application connected to MC55i.

The parameter <current> is volatile, meaning that the default value is restored each time the module is powered down or reset. Therefore, for better control of charging, it is recommended to enter the value every time the module is started.

See [1] for details on AT^SBC.

3.5.3 Battery Pack Characteristics

The charging algorithm has been optimised for a Li-Ion battery pack that meets the characteristics listed below and in [Table 10](#). It is recommended that the battery pack you want to integrate into your MC55i application is compliant with these specifications. This ensures reliable operation, proper charging and, particularly, allows you to monitor the battery capacity using the AT^SBC command (see [\[1\]](#) for details). Failure to comply with these specifications might cause AT^SBC to deliver incorrect battery capacity values.

- Li-Ion or Lithium Polymer battery pack specified for a maximum charging voltage of 4.2V and a capacity higher than 500mAh.
- Since charging and discharging largely depend on the battery temperature, the battery pack should include an NTC resistor. If the NTC is not inside the battery it must be in thermal contact with the battery. The NTC resistor must be connected between BATT_TEMP and GND. Required NTC characteristics are: $10k\Omega \pm 5\% @ 25^{\circ}\text{C}$, $B_{25/85} = 3435K \pm 3\%$ (alternatively acceptable: $10k\Omega \pm 2\% @ 25^{\circ}\text{C}$, $B_{25/50} = 3370K \pm 3\%$). Please note that the NTC is indispensable for proper charging, i.e. the charging process will not start if no NTC is present.
- Ensure that the pack incorporates a protection circuit capable of detecting overvoltage (protection against overcharging), undervoltage (protection against deep discharging) and overcurrent. The circuit must be insensitive to pulsed current.
- On the MC55i module, a built-in measuring circuit constantly monitors the supply voltage. In the event of undervoltage, it causes MC55i to power down. Undervoltage thresholds are specific to the battery pack and must be evaluated for the intended model. When you evaluate undervoltage thresholds, consider both the current consumption of MC55i *and* of the application circuit.
- The internal resistance of the battery and the protection should be as low as possible. It is recommended not to exceed 150m Ω , even in extreme conditions at low temperature. The battery cell must be insensitive to rupture, fire and gassing under extreme conditions of temperature and charging (voltage, current).
- The battery pack must be protected from reverse pole connection. For example, the casing should be designed to prevent the user from mounting the battery in reverse orientation.
- The battery pack must be approved to satisfy the requirements of CE conformity.

[Figure 7](#) shows the circuit diagram of a typical battery pack design that includes the protection elements described above.

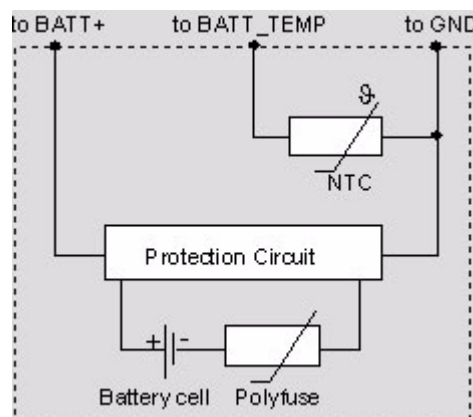

Figure 7: Battery pack circuit diagram

Table 10: Specifications of battery packs suitable for use with MC55i

Battery type	Rechargeable Lithium Ion or Lithium Polymer battery
Nominal voltage	3.6V / 3.7V
Capacity	Min. 500mAh
NTC	10kΩ ± 5% @ 25°C approx. 5kΩ @ 45°C approx. 26.2kΩ @ 0°C B value range: B (25/85)=3423K to B =3435K ± 3%
Overcharge detection voltage	4.325 ± 0.025V
Overdischarge detection voltage	2.4V
Overdischarge release voltage	2.6V
Overcurrent detection	3 ± 0.5A
Overcurrent detection delay time	4 ~ 16ms
Short detection delay time	50µs
Internal resistance	<130mΩ Note: A maximum internal resistance of 150mΩ should not be exceeded even after 500 cycles and under extreme conditions.

3.5.4 Batteries Tested for Use with MC55i

When you choose a battery for your MC55i application you can take advantage of one of the following two batteries offered by VARTA Microbattery GmbH. Both batteries meet all requirements listed above. They have been thoroughly tested by Cinterion Wireless Modules and proved to be suited for MC55i.

- LIP 653450 TC, type Lithium Ion
This battery is listed in the standard product range of VARTA. It is incorporated in a shrink sleeve and has been chosen for integration into the reference setup.
- PLF 503759C.PCM, type PoLiFlex® Lithium Polymer
This battery has been especially designed by VARTA for use with electronic applications like mobile phones, PDAs, MP3 players, security and telematic devices. It has the same properties as the above Li-Ion battery, except that it is type Polymer, is smaller, lighter and comes without casing.

Specifications, construction drawings and sales contacts for both VARTA batteries can be found in [6].

3.5.5 Implemented Charging Technique

If the external charging circuit follows the recommendation of [Figure 40](#), the charging process consists of trickle charging and processor controlled fast charging.

Trickle charging

- Trickle charging starts when the charger is connected to the charger input of the external charging circuit and the module's POWER pin. The charging current depends on the voltage difference between the charger input of the external charging circuit and BATT+ of the module.
- Trickle charging stops when the battery voltage reaches 3.6V.

Fast charging

- After trickle charging has raised the battery voltage to 3.3V, the power ASIC turns on and wakes up the baseband processor. Now, processor controlled fast charging begins.
- However, if the battery was deeply discharged (below 2.2V) the power ASIC does not wake up the baseband processor and fast charging does not begin after the battery voltage has reached 3.3V. In this case, disconnect and reconnect the charger once after the battery voltage has risen above 2.2V.

If the battery voltage is already above 3.3V, processor controlled fast charging starts just after the charger was connected to the charger input of the external charging circuit and the module's POWER pin. If MC55i was in POWER DOWN mode, it turns on and enters the Charge-only mode along with fast charging (see also [Section 3.3.1.3](#)).

Fast charging delivers a constant current until the battery voltage reaches 4.2V and then proceeds with varying charge pulses. As shown in [Figure 8](#), the pulse duty cycle is reduced to adjust the charging procedure and prevent the voltage from overshooting beyond 4.2V. Once the pulse width reaches the minimum of 100ms and the duty cycle does not change for 2 minutes, fast charging is completed.

- Fast charging can only be accomplished at a temperature range from 0°C to +45°C.

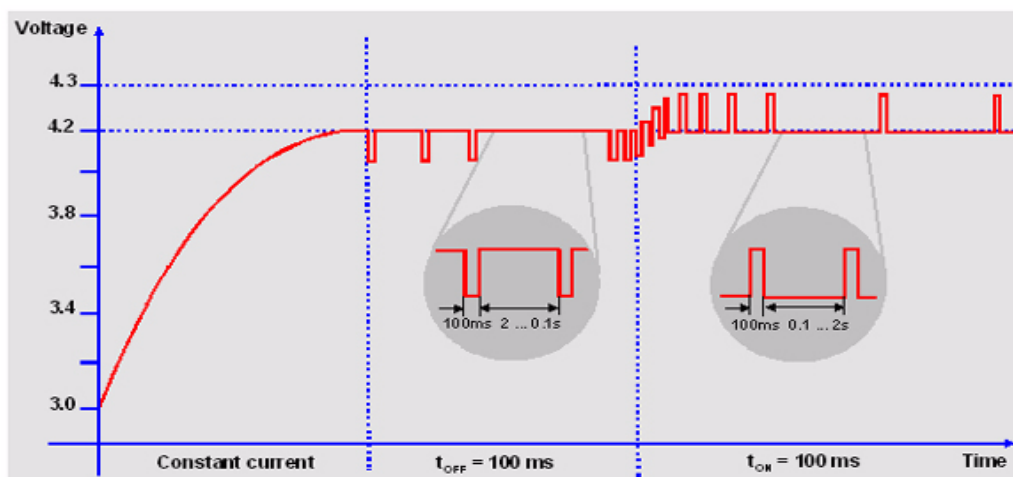

Figure 8: Charging process

Note: Do not connect the charger to the BATT+ lines. Only the charger input of the external charging circuit is intended as input for charging current! The POWER pin of MC55i is the input only for indicating a connected charger! The battery manufacturer must guarantee that the battery complies with the described charging technique.

3.5.6 Operating Modes During Charging

Of course, the battery can be charged regardless of the module's operating mode. When the GSM module is in Normal mode (SLEEP, IDLE, TALK, GPRS IDLE or GPRS DATA mode), it remains operational while charging is in progress (provided that sufficient voltage is applied). The charging process during the Normal mode is referred to as *Charge mode*.

If the charger is connected to the charger input of the external charging circuit and the module's POWER pin while MC55i is in POWER DOWN mode, MC55i goes into *Charge-only mode*.

Table 11: Comparison Charge-only and Charge mode

Mode	How to activate mode	Features
Charge mode	Connect charger to charger input of external charging circuit and module's POWER pin while MC55i is <ul style="list-style-type: none"> operating, e.g. in IDLE or TALK mode in SLEEP mode 	<ul style="list-style-type: none"> Battery can be charged while GSM module remains operational and registered to the GSM network. In IDLE and TALK mode, the serial interfaces are accessible. AT command set can be used to full extent. In the NON-CYCLIC SLEEP mode, the serial interfaces are not accessible at all. During the CYCLIC SLEEP mode it can be used as described in Section 3.6.3.
Charge-only mode	Connect charger to charger input of external charging circuit and module's POWER pin while MC55i is <ul style="list-style-type: none"> in POWER DOWN mode in Normal mode: Connect charger to the POWER pin, then enter AT^SMSO. IMPORTANT: While trickle charging is in progress, be sure that the application is switched off. If the application is fed from the trickle charge current the module might be prevented from proceeding to software controlled charging since the current would not be sufficient.	<ul style="list-style-type: none"> Battery can be charged while GSM module is deregistered from GSM network. Charging runs smoothly due to constant current consumption. The AT interface is accessible and allows to use the commands listed below.

Once the GSM module enters the Charge-only mode, the AT command interface presents an Unsolicited Result Code (URC) which reads:

`^SYSSTART CHARGE-ONLY MODE`

Note that this URC will not appear when autobauding is enabled (due to the missing synchronization between DTE and DCE upon start-up). Therefore, it is recommended to select a fixed baud rate before using the Charge-only mode.

While the Charge-only mode is in progress, you can only use the AT commands listed in [Table 12](#). For further instructions refer to the AT Command Set supplied with your GSM module.

Table 12: AT commands available in Charge-only mode

AT command	Use
AT+CALA	Set alarm time
AT+CCLK	Set date and time of RTC
AT^SBC	Monitor charging process <i>Note: While charging is in progress, no battery capacity value is available. To query the battery capacity disconnect the charger. If the charger connects externally to the host device no charging parameters are transferred to the module. In this case, the command cannot be used.</i>
AT^SCTM	Query temperature, enable/disable URCs to report critical temperature ranges
AT^SMSO	Power down the module. Only functional if the external circuit shown in Figure 9 is implemented (otherwise the module would restart again into Charge-only mode).

To proceed from Charge-only mode to normal operation, it is necessary to drive the ignition line to ground. This must be implemented in your host application as described in [Section 3.3.1.1](#). See also [Section 3.7](#) which summarizes the various options of changing the mode of operation.

If your host application uses the SYNC pin to control a status LED as described in [Section 3.13.2.2](#), please note that the LED is off while the GSM module is in Charge-only mode.

3.5.7 Charger Requirements

If you are using the implemented charging technique the charger must be designed to meet the following requirements:

- Output voltage: 5.5 V...8 V (under load)
- Charge current: limited to 500 mA if the charging circuit uses a Si3441DV MOSFET as specified in [Figure 40](#).
- Voltage spikes that may occur while you connect or disconnect the charger must be limited.
- There must not be any capacitor on the secondary side of the power plug (avoidance of current spikes at the beginning of charging).
- When the current is switched off a voltage peak of 10V is allowed for a maximum 1ms.
- When the current is switched on a spike of 1.6A for 1ms is allowed.

3.5.8 Switch off during Charge-only Mode

To switch off MC55i during Charge-only mode an external circuit will have to be implemented at the module's charging interface as shown in the figure below (see also [Figure 40](#)):

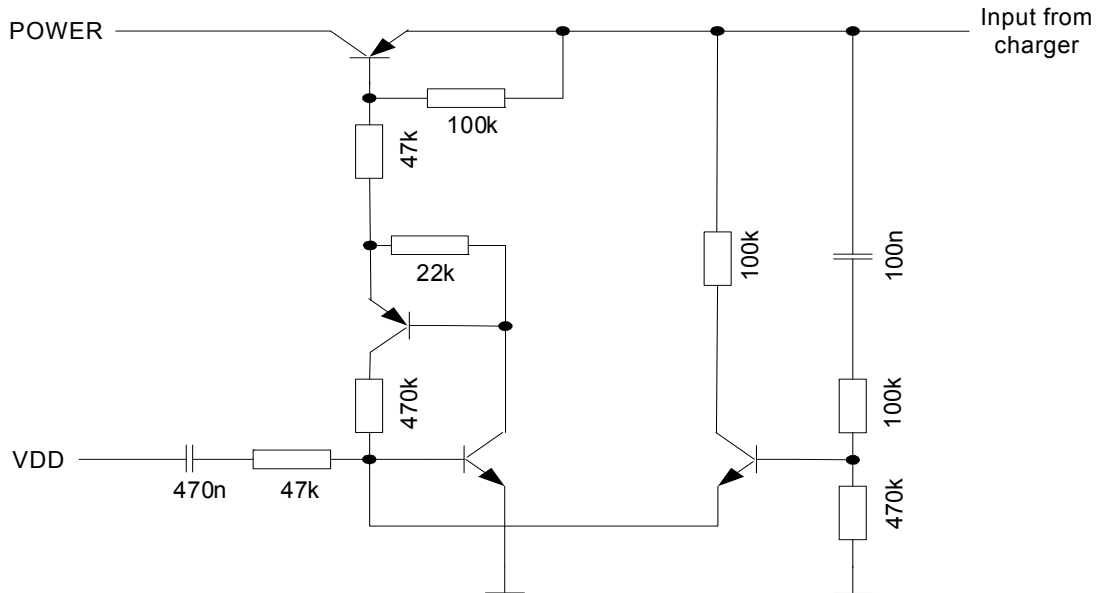

Figure 9: External circuit to switch off MC55i during charging

Alternatively, the charger has to be disconnected, i.e., the charging interface's POWER signal has to be set to low, in order to switch the module off during Charge-only mode.

3.6 Power Saving

SLEEP mode reduces the functionality of the MC55i module to a minimum and, thus, minimizes the current consumption to the lowest level. Settings can be made using the AT+CFUN command. For details see below and [1]. SLEEP mode falls into two categories:

- NON-CYCLIC SLEEP mode AT+CFUN=0
- CYCLIC SLEEP modes, selectable with AT+CFUN=5, 6, 7, 8 or 9.

IMPORTANT: Please keep in mind that power saving works properly only when PIN authentication has been done. If you attempt to activate power saving while the SIM card is not inserted or the PIN not correctly entered (Limited Service), the selected <fun> level will be set, though power saving does not take effect. For the same reason, power saving cannot be used if MC55i operates in Alarm mode.

To check whether power saving is on, you can query the status of AT+CFUN if you have chosen CYCLIC SLEEP mode. If available, you can take advantage of the status LED controlled by the SYNC pin (see Section 3.13.2.2). The LED is off in all SLEEP modes when no activity occurs, but resumes flashing to indicate temporary wake-up states during CYCLIC SLEEP modes. The LED patterns are shown in Table 20.

The wake-up procedures are quite different depending on the selected SLEEP mode. Table 13 compares the wake-up events that can occur in NON-CYCLIC and CYCLIC SLEEP modes.

3.6.1 No Power Saving (AT+CFUN=1)

The functionality level <fun>=1 is where power saving is switched off. This is the default after startup.

3.6.2 NON-CYCLIC SLEEP Mode (AT+CFUN=0)

If level 0 has been selected (AT+CFUN=0), the serial interface is blocked. The module shortly deactivates power saving to listen to a paging message sent from the base station and then immediately resumes power saving. Level 0 is called NON-CYCLIC SLEEP mode, since the serial interface is not alternatingly made accessible as in CYCLIC SLEEP mode.

The first wake-up event fully activates the module, enables the serial interface and terminates the power saving mode. In short, it takes MC55i back to the highest level of functionality <fun>=1.

In NON-CYCLIC mode, the falling edge of the RTS0 or RTS1 lines wakes up the module to <fun>=1. To efficiently use this feature it is recommended to enable hardware flow control (RTS/CTS handshake) as in this case the CTS line notifies the application when the module is ready to send or receive characters. See Section 3.6.6.1 for details.

3.6.3 CYCLIC SLEEP Mode (AT+CFUN=5, 6, 7, 8)

The functionality levels AT+CFUN=5, AT+CFUN=6, AT+CFUN=7 and AT+CFUN=8 are referred to as CYCLIC SLEEP modes. The major benefit of all CYCLIC SLEEP modes is that the serial interface remains accessible, and that, in intermittent wake-up periods, characters can be sent or received without terminating the selected mode.

The CYCLIC SLEEP modes give you greater flexibility regarding the wake-up procedures: For example, in all CYCLIC SLEEP modes, you can enter AT+CFUN=1 to permanently wake up the module. In modes CFUN=7 and 8, MC55i automatically resumes power saving, after you have sent or received a short message, made a call or completed a GPRS transfer. CFUN=5 and 6 do not offer this feature, and therefore, are only supported for compatibility with earlier releases. Please refer to [Table 13](#) for a summary of all modes.

The CYCLIC SLEEP mode is a dynamic process which alternately enables and disables the serial interface. By setting/resetting the CTS signal, the module indicates to the application whether or not the UART is active. The timing of CTS is described below.

Both the application and the module must be configured to use hardware flow control (RTS/CTS handshake). The default setting of MC55i is AT\Q0 (no flow control) which must be altered to AT\Q3. See [\[1\]](#) for details.

Note: If both serial interfaces ASC0 and ASC1 are connected, both are synchronized. This means that SLEEP mode takes effect on both, no matter on which interface the AT command was issued. Although not explicitly stated, all explanations given in this section refer equally to ASC0 and ASC1, and accordingly to CTS0 and CTS1.

3.6.4 CYCLIC SLEEP Mode AT+CFUN=9

Mode AT+CFUN=9 is similar to AT+CFUN=7 or 8, but provides two additional features:

- The time the module stays active after RTS was asserted or after the last character was sent or received, can be configured individually using the command AT^SCFG. Default setting is 2 seconds like in AT+CFUN=7. The entire range is from 0.5 seconds to 1 hour, selectable in tenths of seconds. For details see [\[1\]](#).
- RTS0 and RTS1 are not only used for flow control (as in modes AT+CFUN=5, 6, 7 or 8), but also cause the module to wake up temporarily. See [Section 3.6.6.1](#) for details.

3.6.5 Timing of the CTS Signal in CYCLIC SLEEP Modes

The CTS signal is enabled in synchrony with the module's paging cycle. It goes active low each time when the module starts listening to a paging message block from the base station. The timing of the paging cycle varies with the base station. The duration of a paging interval can be calculated from the following formula:

$4.615 \text{ ms (TDMA frame duration)} * 51 \text{ (number of frames)} * \text{DRX value.}$

DRX (Discontinuous Reception) is a value from 2 to 9, resulting in paging intervals from 0.47 to 2.12 seconds. The DRX value of the base station is assigned by the network operator.

Each listening period causes the CTS signal to go active low: If DRX is 2, the CTS signal is activated every 0.47 seconds, if DRX is 3, the CTS signal is activated every 0.71 seconds and if DRX is 9, the CTS signal is activated every 2.1 seconds.

The CTS signal is active low for 4.6 ms. This is followed by another 4.6 ms UART activity. If the start bit of a received character is detected within these 9.2 ms, CTS will be activated and the proper reception of the character will be guaranteed. CTS will also be activated if any character is to be sent.

After the last character was sent or received the interface will remain active for

- another 2 seconds, if AT+CFUN=5 or 7,
- another 10 minutes, if AT+CFUN=6 or 8,
- or for an individual time defined with AT^SCFG, if AT+CFUN=9. Assertion of RTS has the same effect.

In the pauses between listening to paging messages, while CTS is high, the module resumes power saving and the AT interface is not accessible. See [Figure 12](#) and [Figure 13](#).

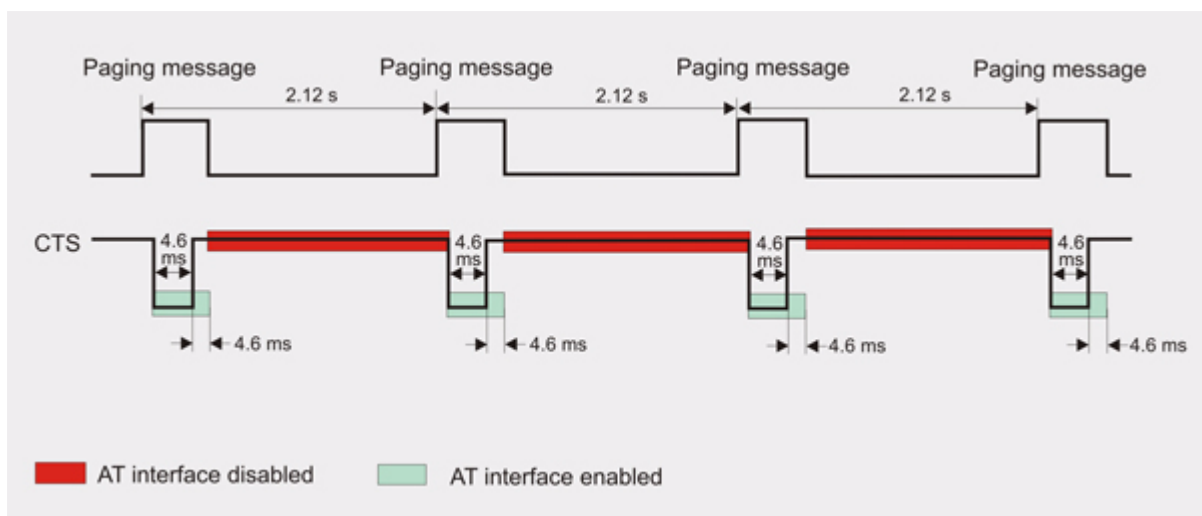

Figure 10: Timing of CTS signal (example for a 2.12 s paging cycle)

Figure 11 illustrates the CFUN=5 and CFUN=7 modes, which reset the CTS signal 2 seconds after the last character was sent or received.

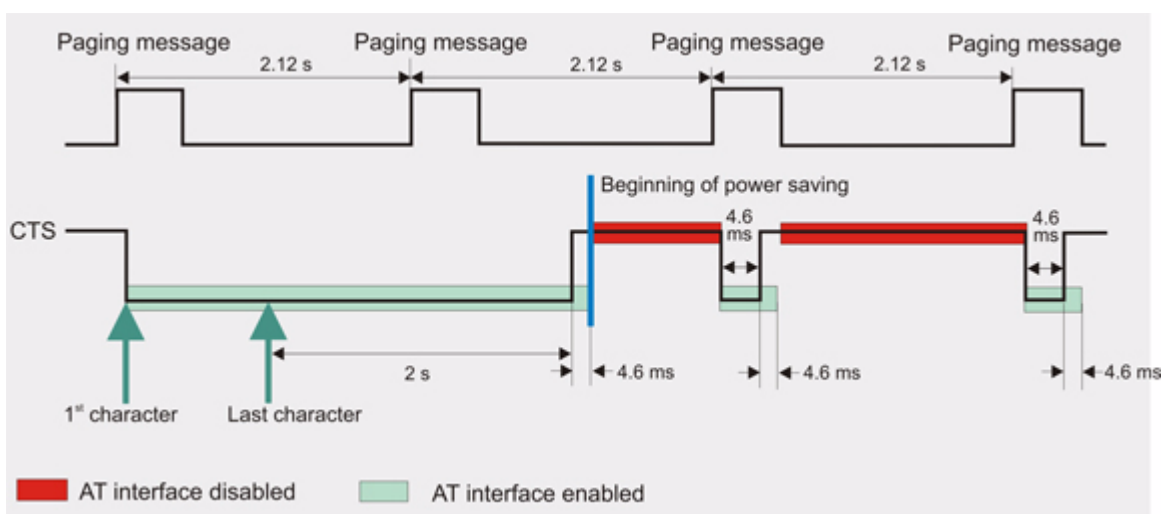

Figure 11: Beginning of power saving if CFUN=5 or 7

3.6.6 Wake up MC55i from SLEEP Mode

A wake-up event is any event that causes the module to draw current. Depending on the selected mode the wake-up event either switches SLEEP mode off and takes MC55i back to AT+CFUN=1, or activates MC55i temporarily without leaving the current SLEEP mode.

Definitions of the state transitions described in [Table 13](#):

- Quit = MC55i exits SLEEP mode and returns to AT+CFUN=1.
- Temporary = MC55i becomes active temporarily for the duration of the event and the mode specific follow-up time after the last character was sent or received on the serial interface.
- No effect = Event is not relevant in the selected SLEEP mode. MC55i does not wake up.

Table 13: Wake-up events in NON-CYCLIC and CYCLIC SLEEP modes

Event	Selected mode AT+CFUN=0	Selected mode AT+CFUN=5 or 6	Selected mode AT+CFUN=7, 8, 9
Ignition line	No effect	No effect	No effect
RTS0 or RTS1 ¹⁾ (falling edge)	Quit + flow control	No effect, RTS is only used for flow control	Mode 7 and 8: No effect, RTS is only used for flow control Mode 9: Temporary + flow control
Unsolicited Result Code (URC)	Quit	Quit	Temporary
Incoming voice or data call	Quit	Quit	Temporary
Any AT command (incl. outgoing voice or data call, outgoing SMS)	Not possible (UART disabled)	Temporary	Temporary
Incoming SMS depending on mode selected by AT+CNMI: AT+CNMI=0,0 (= default, no indication of received SMS)	No effect	No effect	No effect
AT+CNMI=1,1 (= displays URC upon receipt of SMS)	Quit	Quit	Temporary
GPRS data transfer	Not possible (UART disabled)	Temporary	Temporary
RTC alarm ²⁾	Quit	Quit	Temporary
AT+CFUN=1	Not possible (UART disabled)	Quit	Quit

^{1.} See [Section 3.6.6.1](#) on wake-up via RTS.
^{2.} Recommendation: In NON-CYCLIC SLEEP mode, you can set an RTC alarm to wake up MC55i and return to full functionality. This is a useful approach because, in this mode, the AT interface is not accessible.

3.6.6.1 Wake-up via RTS0 and RTS1 (if AT+CFUN=0 or AT+CFUN=9)

During the CYCLIC SLEEP modes 5, 6, 7, and 8, the RTS0 and RTS1 lines are conventionally used for flow control: The assertion of RTS0 or RTS1 indicates that the application is ready to receive data - without waking up the module.

If the module is in CFUN=0 mode the assertion of RTS0 and RTS1 serves as a wake-up event, giving the application the possibility to intentionally terminate power saving. If the module is in CFUN=9 mode, the assertion of RTS0 or RTS1 can be used to temporarily wake up MC55i for the time specified with the AT^SCFG command (default = 2s). In both cases, if RTS0 or RTS1 is asserted while AT+CFUN=0 or AT+CFUN=9 is set, there may be a short delay until the module is able to receive data again. This delay depends on the current module activities (e.g. paging cycle) and may be up to 60ms. The ability to receive data is signaled by CTS0 and CTS1. It is therefore recommended to enable RTS/CTS flow control, not only in CYCLIC SLEEP mode, but also in NON-CYCLIC SLEEP mode.

3.7 Summary of State Transitions (except SLEEP Mode)

The table shows how to proceed from one mode to another (grey column = present mode, white columns = intended modes)

Table 14: State transitions of MC55i (except SLEEP mode)

Further mode →→ Present mode	POWER DOWN	Normal mode ¹	Charge-only mode ²	Charging in normal mode ¹⁾²⁾	Alarm mode
POWER DOWN mode <u>without</u> charger	---	IGT >100 ms at low level	Connect charger to input of ext. charging circuit and POWER pin (high level at POWER)	No direct transition, but via “Charge-only mode” or “Normal mode”	Wake-up from POWER DOWN mode (if activated with AT+CALA)
POWER DOWN mode with charger (high level at POWER pin)	---	IGT (if supply voltage is above 3.0V). No automatic transition, but via Power Down mode without charger)	100ms < IGT < 500ms at low level	IGT >1 s at low level	Wake-up from POWER DOWN mode (if activated with AT+CALA)
Normal mode ¹	AT^SMSO <u>or</u> exceptionally EMERGOFF pin > 10ms at low level	---	No automatic transition, but via “POWER DOWN”	Connect charger to POWER pin (high level at POWER)	AT+CALA followed by AT^SMSO. MC55i enters Alarm mode when specified time is reached.
Charge-only mode ³	Disconnect charger (POWER pin at low level) <u>or</u> AT^SMSO <u>or</u> exceptionally EMERGOFF pin > 10ms at low level	No automatic transition, but via “Charge in Normal mode”	---	IGT >1s at low level	No direct transition
Charging in normal mode ¹⁾²⁾	AT^SMSO → “Charge-only mode”, again AT^SMSO; or exceptionally EMERGOFF pin >10ms at low level	Disconnect charger from input of ext. charging circuit and module’s POWER pin.	AT^SMSO	---	No direct transition
Alarm mode	AT^SMSO <u>or</u> exceptionally EMERGOFF pin > 10ms at low level	IGT >100ms at low level	---	IGT >100ms at low level	

¹. See [Section 3.5.6](#) for details on the charging mode

². Normal mode covers TALK, DATA, GPRS, IDLE and SLEEP modes

³. See [Section 3.5.8](#) for a description of an external circuit required to switch off the module during Charge-only mode.

3.8 RTC Backup

The internal Real Time Clock of MC55i is supplied from a separate voltage regulator in the power supply ASIC which is also active when MC55i is in POWER DOWN status. An alarm function is provided that allows to wake up MC55i without logging on to the GSM network.

In addition, you can use the VDDL P pin on the board-to-board connector to backup the RTC from an external capacitor or a battery (rechargeable or non-chargeable). The capacitor is charged by the BATT+ line of MC55i. If the voltage supply at BATT+ is disconnected the RTC can be powered by the capacitor. The size of the capacitor determines the duration of buffering when no voltage is applied to MC55i, i.e. the greater the capacitor the longer MC55i will save the date and time.

The following figures show various sample configurations. The voltage applied at VDDL P can be in the range from 2 to 5.5V. Please refer to Table 30 for the parameters required.

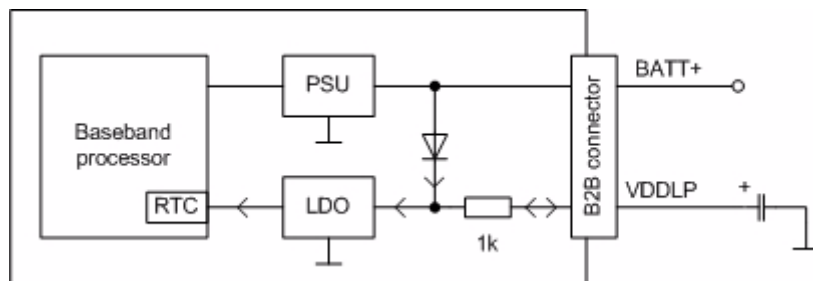

Figure 12: RTC supply from capacitor

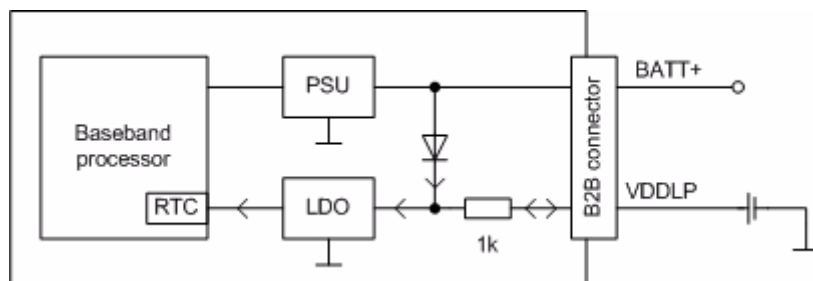

Figure 13: RTC supply from rechargeable battery

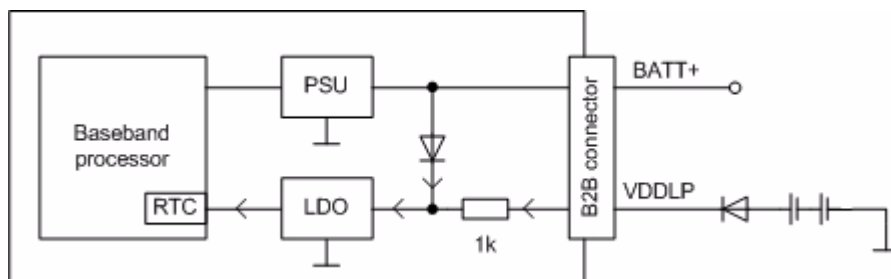

Figure 14: RTC supply from non-chargeable battery

3.9 Serial Interface ASC0

MC55i offers an 8-wire unbalanced, asynchronous modem interface ASC0 conforming to ITU-T V.24 protocol DCE signalling. The electrical characteristics do not comply with ITU-T V.28. The significant levels are 0V (for low data bit or active state) and 2.9V (for high data bit or inactive state). For electrical characteristics please refer to [Table 32](#).

MC55i is designed for use as a DCE. Based on the conventions for DCE-DTE connections it communicates with the customer application (DTE) using the following signals:

- Port TXD @ application sends data to the module's TXD0 signal line
- Port RXD @ application receives data from the module's RXD0 signal line

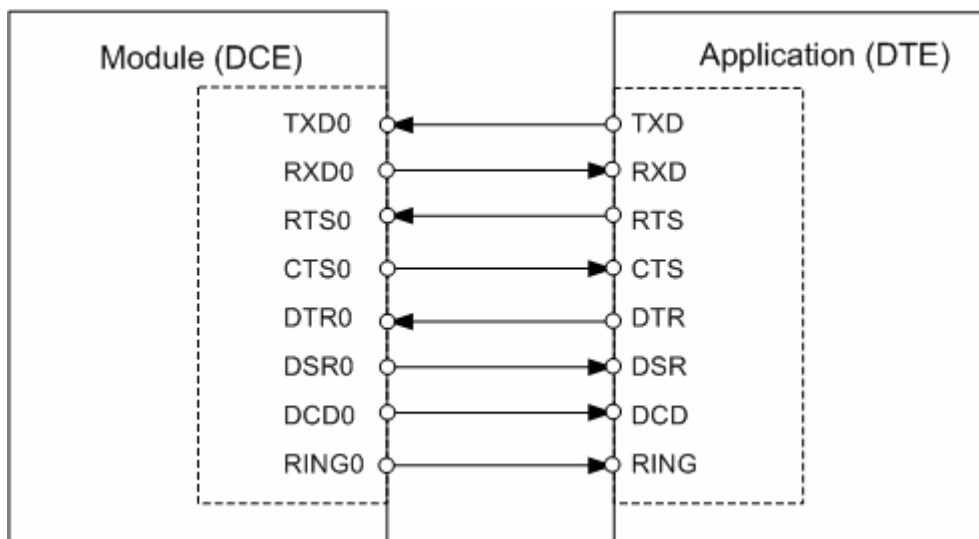

Figure 15: Serial interface ASC0

Features:

- Includes the data lines TXD0 and RXD0, the status lines RTS0 and CTS0 and, in addition, the modem control lines DTR0, DSR0, DCD0 and RING0.
- ASC0 is primarily designed for controlling voice calls, transferring CSD, fax and GPRS data and for controlling the GSM module with AT commands.
- Full Multiplex capability allows the interface to be partitioned into three virtual channels, yet with CSD and fax services only available on the first logical channel. Please note that when the ASC0 interface runs in Multiplex mode, ASC1 cannot be used. For more details on Multiplex mode see [\[10\]](#).
- The DTR0 signal will only be polled once per second from the internal firmware of MC55i.
- The RING0 signal serves to indicate incoming calls and other types of URCs (Unsolicited Result Code). It can also be used to send pulses to the host application, for example to wake up the application from power saving state. See [\[1\]](#) for details on how to configure the RING0 line by AT[^]SCFG.
- Configured for 8 data bits, no parity and 1 stop bit.
- ASC0 can be operated at fixed bit rates from 300 bps to 230400 bps.
- Autobauding supports bit rates from 1200 to 230400 bps.
- Autobauding is not compatible with multiplex mode.
- Supports RTS0/CTS0 hardware flow control and XON/XOFF software flow control.

Table 15: DCE-DTE wiring of ASC0

V.24 circuit	DCE		DTE	
	Pin function	Signal direction	Pin function	Signal direction
103	TXD0	Input	TXD	Output
104	RXD0	Output	RXD	Input
105	RTS0	Input	RTS	Output
106	CTS0	Output	CTS	Input
108/2	DTR0	Input	DTR	Output
107	DSR0	Output	DSR	Input
109	DCD0	Output	DCD	Input
125	RING0	Output	RING	Input

3.10 Serial Interface ASC1

MC75 offers a 4-wire unbalanced, asynchronous modem interface ASC1 conforming to ITU-T V.24 protocol DCE signalling. The electrical characteristics do not comply with ITU-T V.28. The significant levels are 0V (for low data bit or active state) and 2.9V (for high data bit or inactive state). For electrical characteristics please refer to [Table 32](#).

MC55i is designed for use as a DCE. Based on the conventions for DCE-DTE connections it communicates with the customer application (DTE) using the following signals:

- Port TXD @ application sends data to module's TXD1 signal line
- Port RXD @ application receives data from the module's RXD1 signal line

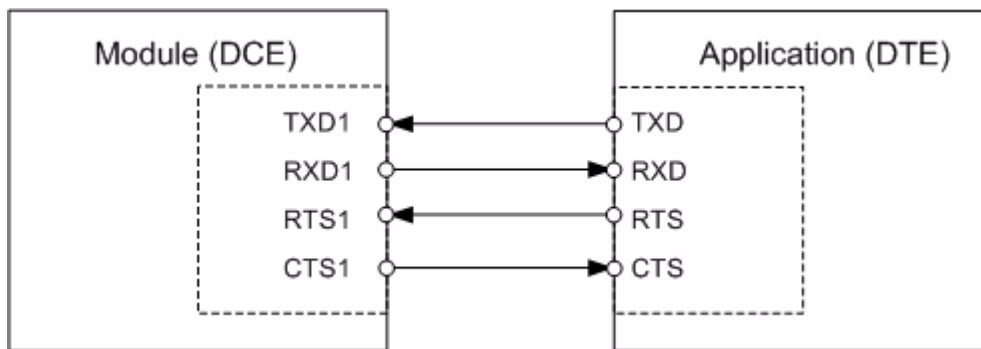

Figure 16: Serial interface ASC1

Features

- Includes only the data lines TXD1 and RXD1 plus RTS1 and CTS1 for hardware hand-shake.
- On ASC1 no RING line is available. The indication of URCs on the second interface depends on the settings made with the AT^SCFG command. For details refer to [\[1\]](#).
- Configured for 8 data bits, no parity and 1 or 2 stop bits.
- ASC1 can be operated at fixed bit rates from 300 bps to 230400 bps. Autobauding is not supported on ASC1.
- Supports RTS1/CTS1 hardware flow control and XON/XOFF software flow control.

Table 16: DCE-DTE wiring of ASC1

V.24 circuit	DCE		DTE	
	Pin function	Signal direction	Pin function	Signal direction
103	TXD1	Input	TXD	Output
104	RXD1	Output	RXD	Input
105	RTS1	Input	RTS	Output
106	CTS1	Output	CTS	Input

3.11 Audio interfaces

MC55i comprises three audio interfaces available on the board-to-board connector:

- Two analog audio interfaces, each with a balanced analog microphone input and a balanced analog earpiece output. The second analog interface provides a supply circuit to feed an active microphone.
- Serial digital audio interface (DAI) using PCM (Pulse Code Modulation) to encode analog voice signals into digital bit streams.

This means you can connect up to three audio devices in any combination, although analog and digital audio cannot be operated at the same time. Using the AT^SAIC command you can easily switch back and forth.

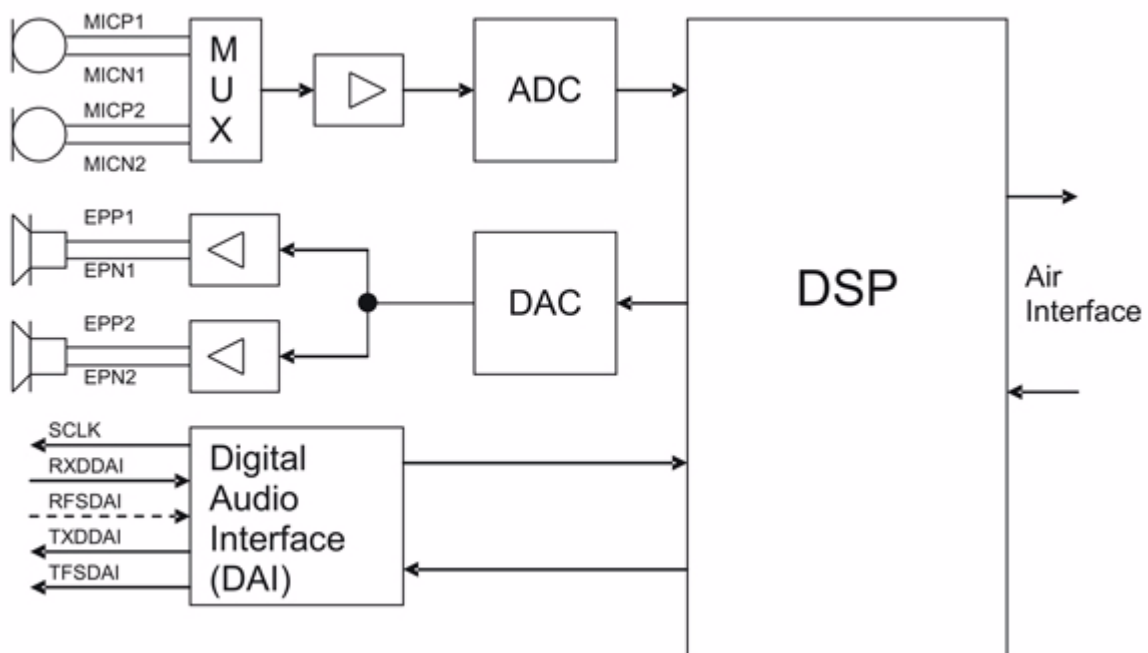

Figure 17: Audio block diagram

MC55i offers six audio modes which can be selected with the AT^SNFS command, no matter which of the three interfaces is currently active. The electrical characteristics of the voiceband part vary with the audio mode. For example, sending and receiving amplification, sidetone paths, noise suppression etc. depend on the selected mode and can be altered with AT commands (except for mode 1).

On each audio interface you can use all audio AT commands specified in [1] to alter parameters. The only exception are the DAC and ADC gain amplifier attenuation <outBbcGain> and <inBbcGain> which cannot be modified when the digital audio interface is used, since in this case the DAC and ADC are switched off.

Please refer to [Section 3.11](#) for specifications of the audio interface and an overview of the audio parameters. Detailed instructions on using AT commands are presented in [1]. [Table 35](#) summarizes the characteristics of the various audio modes and shows what parameters are supported in each mode.

When shipped from factory, all audio parameters of MC55i are set to interface 1 and audio mode 1. This is the default configuration optimised for the Votronic HH-SI-30.3/V1.1/0 handset and used for type approving the Cinterion Wireless Modules reference configuration. Audio mode 1 has fix parameters which cannot be modified. To adjust the settings of the Votronic handset simply change to another audio mode.

In transmit direction, all audio modes contain internal scaling factors (digital amplification) that are not accessible. In case of digital signal input via the DAI, these scaling factors are set to 0dB, so that no further correction using the AT^SNFI parameter <inCalibrate> is required. <inCalibrate> can be left at its default value (=32767).

3.11.1 Microphone Circuit

Interface 1

This interface has no microphone supply circuit and therefore, has an impedance of 50k Ω . When connecting a microphone or another signal source to interface 1 you are required to add two 100 nF capacitors, one to each line.

Interface 2

This interface comes with a microphone supply circuit and can be used to feed an active microphone. It has an impedance of 2k Ω . If you do not use it or if you want to connect another type of signal source, for example, an op amp or a dynamic microphone, it needs to be decoupled with capacitors. The power supply can be switched off and on by using the command AT^SNFM. For details see [1].

Figure 18 shows the microphone inputs at both analog interfaces of MC55i.

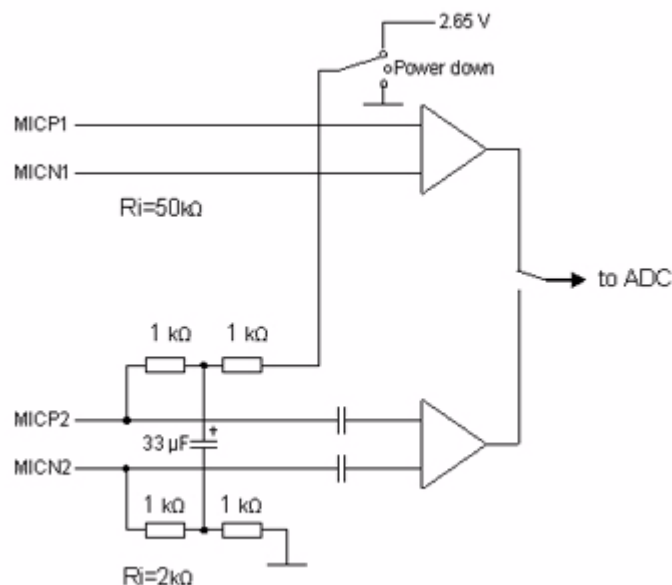

Figure 18: Schematic of microphone inputs

3.11.2 Speech Processing

The speech samples from the ADC or DAI are handled by the DSP of the baseband controller to calculate e.g. amplifications, sidetone, echo cancellation or noise suppression depending on the configuration of the active audio mode. These processed samples are passed to the speech encoder. Received samples from the speech decoder are passed to the DAC or DAI after post processing (frequency response correction, adding sidetone etc.).

Full rate, half rate, enhanced full rate, adaptive multi rate (AMR), speech and channel encoding including voice activity detection (VAD) and discontinuous transmission (DTX) and digital GMSK modulation are also performed on the GSM baseband processor.

Customer specific audio parameters can be evaluated and supplied by Cinterion Wireless Modules on request. These parameters can be downloaded to MC55i using an AT command. For further information contact your Cinterion Wireless Modules distributor.

3.11.3 DAI Timing

To support the DAI function, MC55i integrates a simple four-line serial interface with one input data line (RXDDAI) and three lines for output data, clock and frames (TXDDAI, SCLK and TFSDAI). The input RFSDAI line is reserved for future use.

The SCLK clock signal is an output, generating a 256-kHz-bit-clock as master. There is a so called "long frame synchronization" signal available for both transmit and receive directions at the TFSDAI pin.

The 4-wire PCM interface uses the SCLK line for bit shifting, the TFSDAI line to synchronize transmission and receipt of data simultaneously as well as the TXDDAI and RXDDAI lines to transfer data.

Data transfer between MC55i and an application is initiated via a pulse of TFSDAI. The duration of the TFSDAI pulse is 16 SCLK periods, starting at the rising edge of SCLK. During these 16 SCLK cycles, the 16-bit sample will be transferred over the TXDDAI line and received via RXDDAI. The next samples will be transferred after the next TFSDAI pulse. The TFSDAI pulses occur every 125 μ s - synchronized with the GSM data flow. The timing characteristics of both data transfer directions are shown in [Figure 19](#).

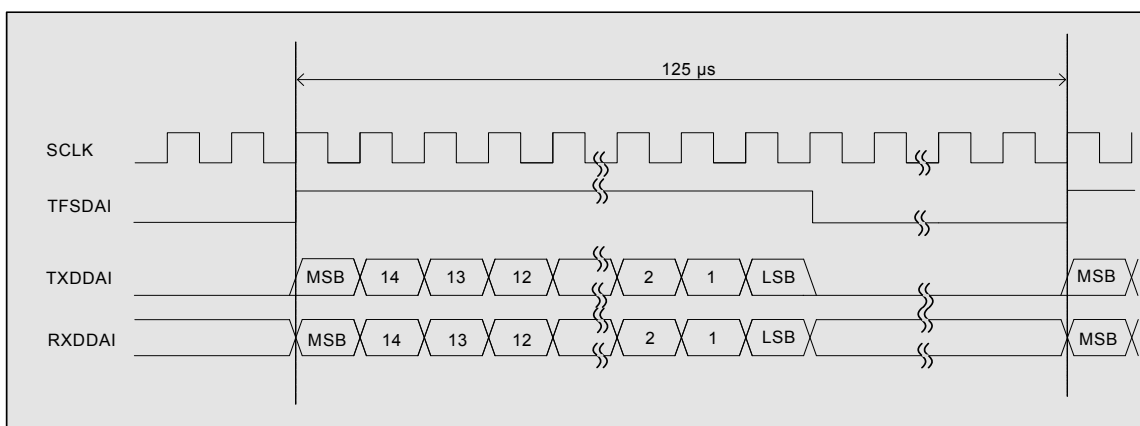

Figure 19: DAI timing

3.12 SIM Interface

The baseband processor has an integrated SIM interface compatible with the ISO 7816 IC Card standard. This is wired to the host interface (board-to-board connector) in order to be connected to an external SIM card holder. Six pins on the board-to-board connector are reserved for the SIM interface. MC55i supports and automatically detects 3.0V as well as 1.8V SIM cards.

The CCIN pin serves to detect whether a tray (with SIM card) is present in the card holder. Using the CCIN pin is mandatory for compliance with the GSM 11.11 recommendation if the mechanical design of the host application allows the user to remove the SIM card during operation. See [Section 3.12.1](#) for details.

Table 17: Signals of the SIM interface (board-to-board connector)

Signal	Description
CCGND	Separate ground connection for SIM card to improve EMC.
CCCLK	Chipcard clock, various clock rates can be set in the baseband processor.
CCVCC	SIM supply voltage from PSU-ASIC
CCIO	Serial data line, input and output.
CCRST	Chipcard reset, provided by baseband processor
CCIN	Input on the baseband processor for detecting a SIM card tray in the holder. The CCIN pin is mandatory for applications that allow the user to remove the SIM card during operation. The CCIN pin is solely intended for use with a SIM card. It must not be used for any other purposes. Failure to comply with this requirement may invalidate the type approval of MC55i.

It is recommended that the total cable length between the board-to-board connector pins on MC55i and the pins of the SIM card holder does not exceed 200 mm in order to meet the specifications of 3GPP TS 51.010-1 and to satisfy the requirements of EMC compliance.

To avoid possible cross-talk from the CCCLK signal to the CCIO signal be careful that both lines are not placed closely next to each other. A useful approach is using the CCGND line to shield the CCIO line from the CCCLK line.

3.12.1 Requirements for using the CCIN Pin

According to ISO/IEC 7816-3 the SIM interface must be immediately shut down once the SIM card is removed during operation. Therefore, the signal at the CCIN pin must go low *before* the SIM card contacts are mechanically detached from the SIM interface contacts. This shut-down procedure is particularly required to protect the SIM card as well as the SIM interface of MC55i from damage.

An appropriate SIM card detect switch is required on the card holder. For example, this is true for the model supplied by Molex, which has been tested to operate with MC55i and is part of the Cinterion Wireless Modules reference equipment submitted for type approval. Molex ordering number is 91228-0001, see also [Chapter 9](#).

The module's startup procedure involves a SIM card initialisation performed within 1 second after getting started. An important issue is whether the initialisation procedure ends up with a high or low level of the CCIN signal:

- If, during startup of MC55i, the CCIN signal on the SIM interface is high, then the status of the SIM card holder can be recognized each time the card is inserted or ejected.
A low level of CCIN indicates that no SIM card tray is inserted into the holder. In this case, the module keeps searching, at regular intervals, for the SIM card. Once the SIM card tray with a SIM card is inserted, CCIN is taken high again.
- If, during startup of MC55i, the CCIN signal is low, the module will also attempt to initialise the SIM card. In this case, the initialisation will only be successful when the card is present. If the SIM card initialisation has been done, but the card is no more operational or removed, then the module will never search again for a SIM card and only emergency calls can be made.

Removing and inserting the SIM card during operation requires the software to be reinitialised. Therefore, after reinserting the SIM card it is necessary to restart MC55i.

It is strongly recommended to connect the contacts of the SIM card detect switch to the CCIN input and to the CCVCC output of the module as illustrated in the sample diagram in [Figure 20](#).

Note: No guarantee can be given, nor any liability accepted, if loss of data is encountered after removing the SIM card during operation.

Also, no guarantee can be given for properly initialising any SIM card that the user inserts after having removed a SIM card during operation. In this case, the application must restart MC55i.

3.12.2 Design Considerations for SIM Card Holder

The schematic below is a sample configuration that illustrates the Molex SIM card holder located on the DSB45 Support Box (evaluation kit used for type approval of the MC55i reference setup, see [3]). X503 is the designation used for the SIM card holder in [3].

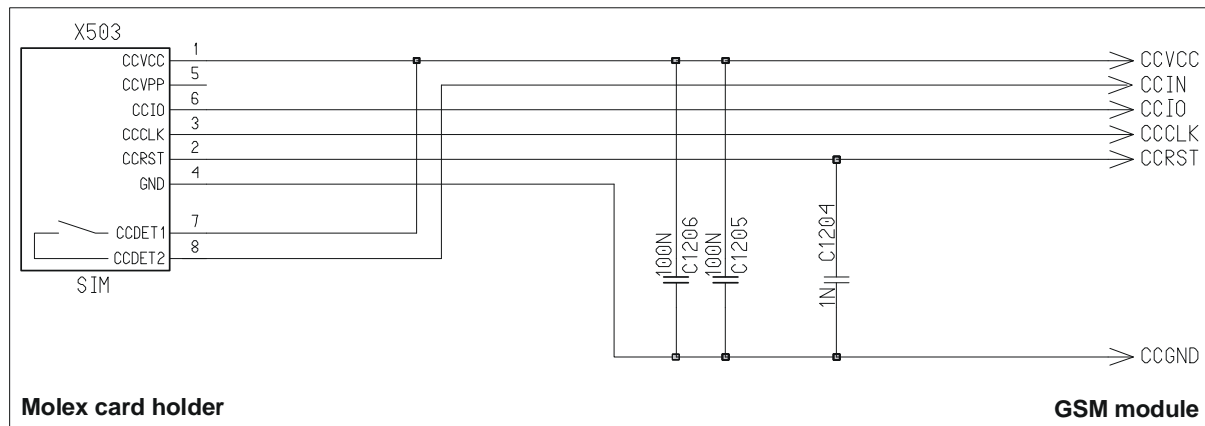

Figure 20: SIM card holder of DSB45 Support Box

Table 18: Pin assignment of Molex SIM card holder on DSB45 Support Box

Pin no.	Signal name	I/O	Function
1	CCVCC	I	Supply voltage for SIM card, generated by the GSM module
2	CCRST	I	Chip card reset, prompted by the GSM module
3	CCCLK	I	Chip card clock
4	CCGND	-	Individual ground line for the SIM card to improve EMC
5	CCVPP	-	Not connected
6	CCIO	I/O	Serial data line, bi-directional
7	CCDET1	-	Connect to CCVCC
8	CCDET2		Connects to the CCIN input of the GSM module. Serves to recognize whether a SIM card is in the holder.

Pins 1 through 8 (except for 5) are the minimum requirement according to the GSM Recommendations, where pins 7 and 8 are needed for SIM card tray detection through the CCIN pin.

Place the capacitors C1205 and C1206 (or instead one capacitor of 200nF) as close as possible to the pins 1 (CCVCC) and 4 (GND) of the card holder. Connect the capacitors to the pins via low resistance tracks.

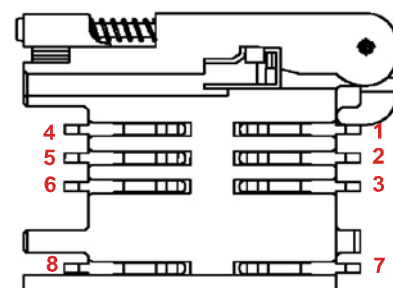

Figure 21: Pin numbers of Molex SIM card holder on DSB45 Support Box

3.13 Control signals

3.13.1 Inputs

Table 19: Input control signals of the MC55i module

Signal	Pin	Pin status	Function	Remarks
Ignition	IGT	Low	Power up MC55i	Active low $\geq 100\text{ms}$ (Open drain/collector driver to GND required in cellular device application). <i>Note: If a charger and a battery is connected to the customer application the IGT signal must be 1s minimum.</i>
		Left open or high impedance	No operation	
Emergency shutdown	EMERG-OFF	Low	Power down MC55i	Active low $\geq 10\text{ms}$ (Open drain/collector driver to GND required in cellular device application). Switches the module off immediately.
		Left open or high impedance	No operation	

3.13.2 Outputs

3.13.2.1 Synchronization Signal

The SYNC pin can adopt two different operating modes which you can select by using the AT^SSYNC command. For details see also [1]. The mode AT^SSYNC=0 (factory default) enables the SYNC signal to indicate that a transmit burst is occurring, and hence, more current flows. The mode AT^SSYNC=1 enables the SYNC pin to drive a status LED as described in Section 3.13.2.2.

Mode AT^SSYNC=0 is recommended if you want your application to use the synchronization signal for better power supply control. Your platform design shall be such that the incoming signal accommodates sufficient power supply to the MC55i module if required because of the transmit burst. This can be achieved by lowering the current drawn from other components installed in your application.

States of the SYNC pin if AT^SSYNC=0: High level indicates increased power consumption during transmission. The timing of the synchronization signal is shown below.

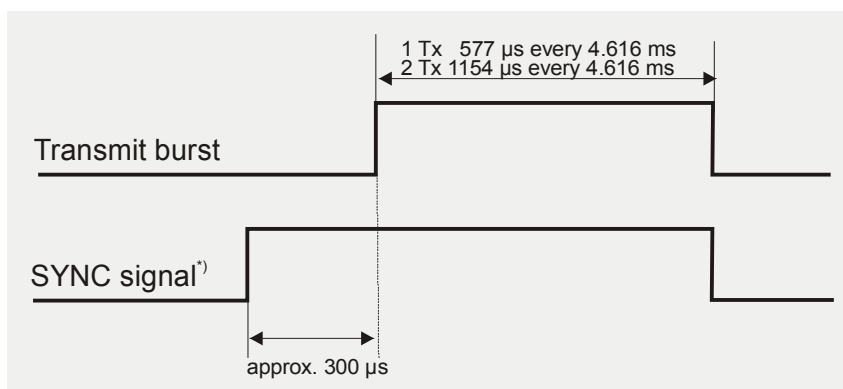

^{*)} The duration of the SYNC signal is always the same, no matter whether the traffic or the access burst are active.

Figure 22: SYNC signal during transmit burst

3.13.2.2 Using the SYNC Pin to Control a Status LED

As an alternative to generating the synchronization signal, the SYNC pin can be used to drive a status LED on your application platform. To avail of this feature you need to set `AT^SSYNC=1`. For details see [1].

Especially in the development and test phase of an application, system integrators are advised to use the LED mode of the SYNC pin in order to evaluate their product design and identify the source of errors.

During the transition from one LED pattern to another the "on" and/or "off" periods of the LED may vary in length. This is because an event that triggers the change may occur any time and, thus, truncate the current LED pattern at any point.

States of the SYNC pin (if `AT^SSYNC=1` and LED connected as illustrated in [Figure 23](#): LED Off = SYNC pin low. LED On = SYNC pin high

Table 20: Coding of the status LED

LED mode	Operating status of MC55i
Permanently off	MC55i is in one of the following modes: <ul style="list-style-type: none"> • POWER DOWN mode • ALARM mode • CHARGE-ONLY mode • NON-CYCLIC SLEEP mode • CYCLIC SLEEP mode with no temporary wake-up event¹
600 ms on / 600 ms off	Limited Network Service: No SIM card inserted or no PIN entered, or network search in progress, or ongoing user authentication, or network login in progress.
75 ms on / 3 s off	IDLE mode: The mobile is logged to the network (monitoring control channels and user interactions). No call in progress.
75 ms on / 75 ms off / 75 ms on / 3 s off	One or more GPRS contexts activated.
0.5 s on / off depending on transmission activity	Packet switched data transfer in progress. LED goes on within 1 second after data packets were exchanged.
Permanently on	Depending on type of call: <i>Voice call:</i> Connected to remote party. <i>CSD call:</i> Connected to remote party or exchange of parameters while setting up or disconnecting a call.

¹. When a temporary wake-up event (a call, a URC, a packet switched transfer) occurs in CYCLIC SLEEP mode the LED flashes according to the patterns listed above. See [Table 13](#) for details on the various SLEEP modes and wake-up events.

To operate the LED a buffer, e.g. a transistor or gate, must be included in your application. A sample configuration can be gathered from [Figure 23](#). Power consumption in the LED mode is the same as for the synchronization signal mode. For details see [Table 32](#), SYNC pin.

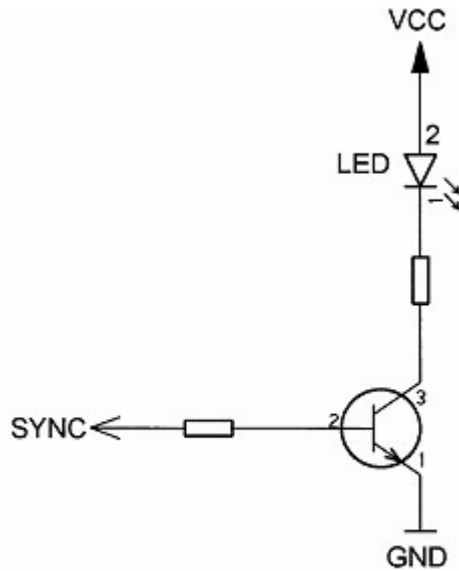

Figure 23: LED Circuit (Example)

3.13.2.3 Behavior of the RING0 Line (ASC0 Interface only)

The RING0 line is available on the first serial interface (ASC0). The signal serves to indicate incoming calls and other types of URCs (Unsolicited Result Code).

Although not mandatory for use in a host application, it is strongly suggested that you connect the RING0 line to an interrupt line of your application. In this case, the application can be designed to receive an interrupt when a falling edge on RING0 occurs. This solution is most effective, particularly, for waking up an application from power saving. Note that if the RING0 line is not wired, the application would be required to permanently poll the data and status lines of the serial interface at the expense of a higher current consumption. Therefore, utilizing the RING0 line provides an option to significantly reduce the overall current consumption of your application.

The behavior of the RING0 line varies with the type of event:

- When a voice/fax/data call comes in the RING0 line goes low for 1s and high for another 4s. Every 5 seconds the ring string is generated and sent over the RXD0 line. If there is a call in progress and call waiting is activated for a connected handset or hands-free device, the RING0 line switches to ground in order to generate acoustic signals that indicate the waiting call.

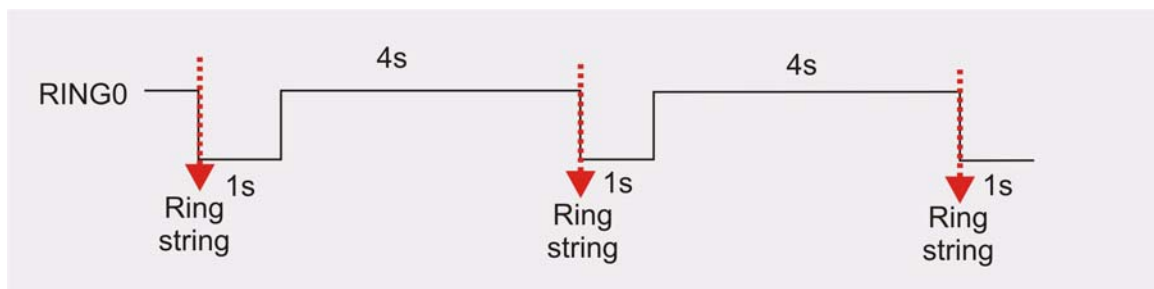

Figure 24: Incoming voice call

- All other types of Unsolicited Result Codes (URCs) also cause the RING0 line to go low, however for 1 second only.

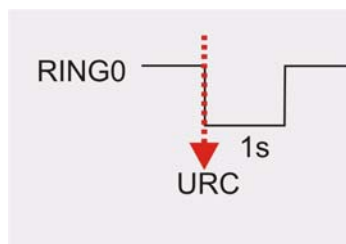

Figure 25: URC transmission

Table 21: ASC0 ring signal

Function	Pin	Status	Description
Ring indication	GSM_RING0	0	Indicates an incoming call or URC. If in NON-CYCLIC SLEEP mode CFUN=0 or CYCLIC SLEEP mode CFUN=5 or 6, the module is caused to wake up to full functionality. If CFUN=7 or 8, power saving is resumed after URC transmission or end of call.
		1	No operation

4 Antenna Interface

The RF interface has an impedance of 50Ω. MC55i is capable of sustaining a total mismatch at the antenna connector or pad without any damage, even when transmitting at maximum RF power.

The external antenna must be matched properly to achieve best performance regarding radiated power, DC-power consumption and harmonic suppression. Matching networks are not included on the MC55i PCB and should be placed in the host application.

Regarding the return loss MC55i provides the following values:

Table 22: Return loss

State of module	Return loss of module	Recommended return loss of application
Receive	$\geq 8\text{dB}$	$\geq 12\text{dB}$
Transmit	not applicable	$\geq 12\text{dB}$
Idle	$\leq 5\text{dB}$	not applicable

The connection of the antenna or other equipment must be decoupled from DC voltage. This is necessary because the antenna connector is DC coupled to ground via an inductor for ESD protection.

4.1 Antenna Installation

To suit the physical design of individual applications MC55i offers two alternative approaches to connecting the antenna:

- Recommended approach: U.FL-R-SMT antenna connector from Hirose assembled on the component side of the PCB (top view on MC55i). See [Section 4.1.2](#) for details.
- Antenna pad and grounding plane placed on the bottom side. See [Section 4.1.1](#).

The U.FL-R-SMT connector has been chosen as antenna reference point (ARP) for the Cinterion Wireless Modules reference equipment submitted to type approve MC55i. All RF data specified throughout this manual are related to the ARP. For compliance with the test results of the Cinterion Wireless Modules type approval you are advised to give priority to the connector, rather than using the antenna pad.

IMPORTANT: Both solutions can only be applied alternatively. This means, whenever an antenna is plugged to the Hirose connector, the pad must not be used. Vice versa, if the antenna is connected to the pad, then the Hirose connector must be left empty.

Antenna connected to Hirose connector:

Antenna connected to pad:

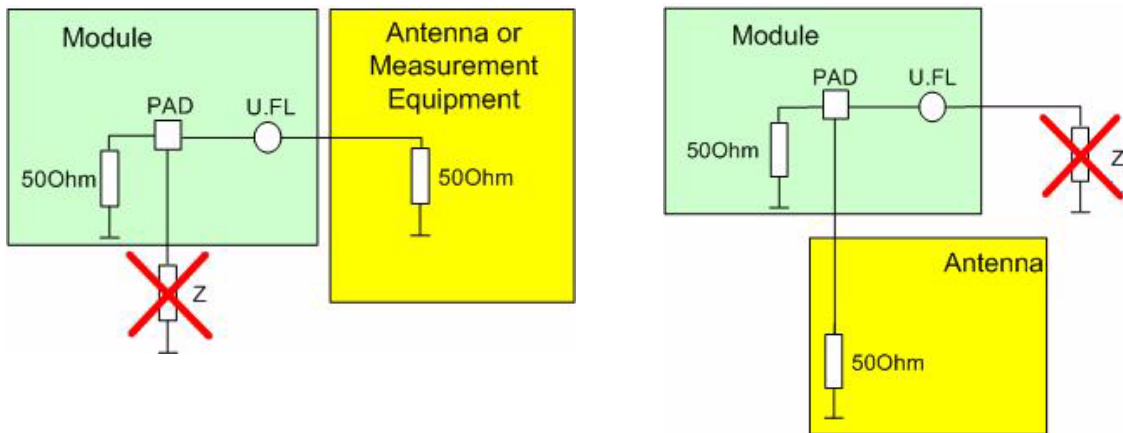

Figure 26: Never use antenna connector and antenna pad at the same time

No matter which option you choose, ensure that the antenna pad does not come into contact with the holding device or any other components of the host application. It needs to be surrounded by a restricted area filled with air, which must also be reserved 0.8 mm in height.

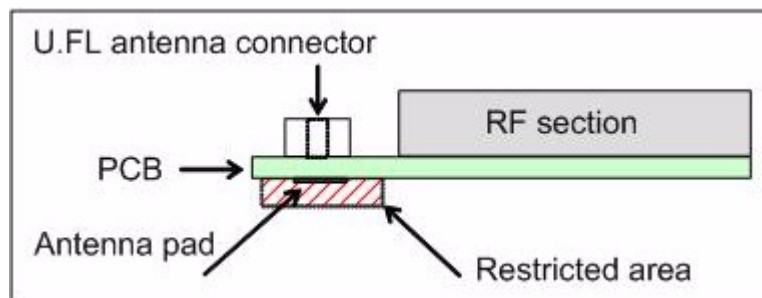

Figure 27: Restricted area around antenna pad

4.1.1 Antenna Pad

The antenna can be soldered to the pad, or attached via contact springs. To help you ground the antenna, MC55i comes with a grounding plane located close to the antenna pad.

When you decide to use the antenna pad take into account that the pad has not been intended as antenna reference point (ARP) for the MC55i type approval. The antenna pad is provided only as an alternative option which can be used, for example, if the recommended Hirose connection does not fit into your antenna design.

Also, consider that according to the GSM recommendations TS 45.005 and TS 51.010-01 a 50Ω connector is mandatory for type approval measurements. This requires GSM devices with an integral antenna to be temporarily equipped with a suitable connector or a low loss RF cable with adapter.

To prevent damage to the module and to obtain long-term solder joint properties you are advised to maintain the standards of good engineering practice for soldering.

MC55i material properties:

MC55i PCB: FR4

Antenna pad: Gold plated pad

4.1.1.1 Suitable Cable Types

For direct solder attachment, we suggest to use the following cable types:

RG316/U 50Ω coaxial cable

1671A 50Ω coaxial cable

Suitable cables are offered, for example, by IMS Connector Systems. For further details and other cable types please contact <http://www.imscs.com>.

4.1.2 Hirose Antenna Connector

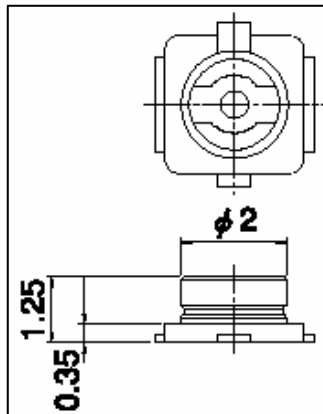

Figure 28: Mechanical dimensions of U.FL-R-SMT connector

Table 23: Product specifications of U.FL-R-SMT connector

Item	Specification	Conditions
<i>Ratings</i>		
Nominal impedance	50 Ω	Operating temp: -40°C to +90°C Operating humidity: max. 90%
Rated frequency	DC to 6 GHz	
<i>Mechanical characteristics</i>		
Female contact holding force	0.15 N _{min}	Measured with a ϕ 0.475 pin gauge
Repetitive operation	Contact resistance: Centre 25 m Ω Outside 15 m Ω	30 cycles of insertion and disengagement
Vibration	No momentary disconnections of 1 μ s; No damage, cracks and looseness of parts	Frequency of 10 to 100 Hz, single amplitude of 1.5 mm, acceleration of 59 m/s ² , for 5 cycles in the direction of each of the 3 axes
Shock	No momentary disconnections of 1 μ s. No damage, cracks and looseness of parts.	Acceleration of 735 m/s ² , 11 ms duration for 6 cycles in the direction of each of the 3 axes
<i>Environmental characteristics</i>		
Humidity resistance	No damage, cracks and looseness of parts. Insulation resistance: 100 M Ω min. at high humidity 500 M Ω min when dry	Exposure to 40°C, humidity of 95% for a total of 96 hours
Temperature cycle	No damage, cracks and looseness of parts. Contact resistance: Centre 25 m Ω Outside 15 m Ω	Temperature: +40°C → 5 to 35°C → +90°C → 5 to 35°C Time: 30 min. → within 5 min. → 30 min. → within 5 min
Salt spray test	No excessive corrosion	48 hours continuous exposure to 5% salt water

Table 24: Material and finish of U.FL-R-SMT connector and recommended plugs

Part	Material	Finish
Shell	Phosphor bronze	Silver plating
Male centre contact	Brass	Gold plating
Female centre contact	Phosphor bronze	Gold plating
Insulator	Plug: PBT Receptacle: LCP	Black Beige

Mating plugs and cables can be chosen from the Hirose U.FL Series. Examples are shown below and listed in [Table 25](#). For latest product information please contact your Hirose dealer or visit the Hirose home page, for example <http://www.hirose.com>.

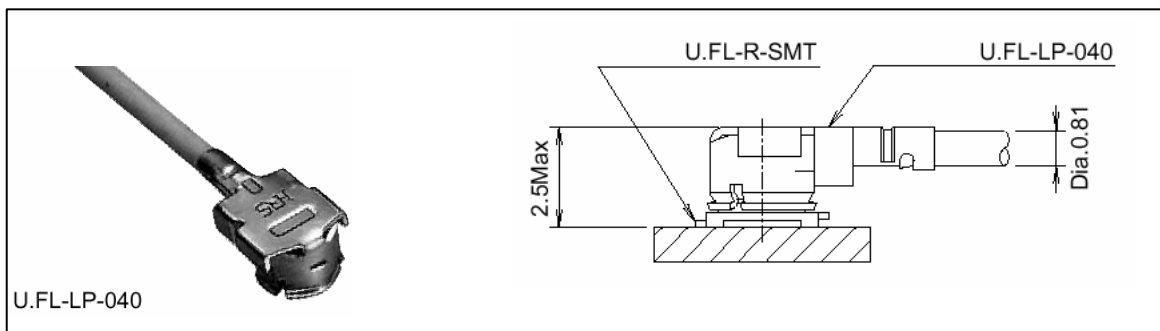

Figure 29: U.FL-R-SMT connector with U.FL-LP-040 plug

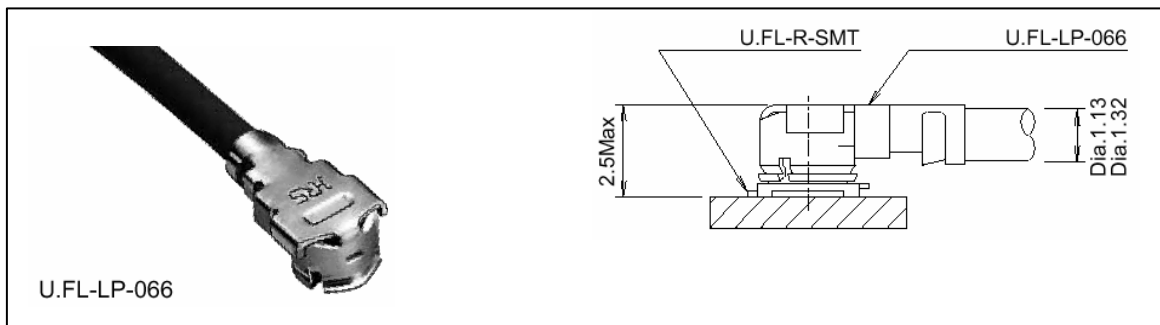

Figure 30: U.FL-R-SMT connector with U.FL-LP-066 plug

In addition to the connectors illustrated above, the U.FL-LP-(V)-040(01) version is offered as an extremely space saving solution. This plug is intended for use with extra fine cable (up to $\varnothing 0.81$ mm) and minimizes the mating height to 2 mm. See Figure 31 which shows the Hirose datasheet.

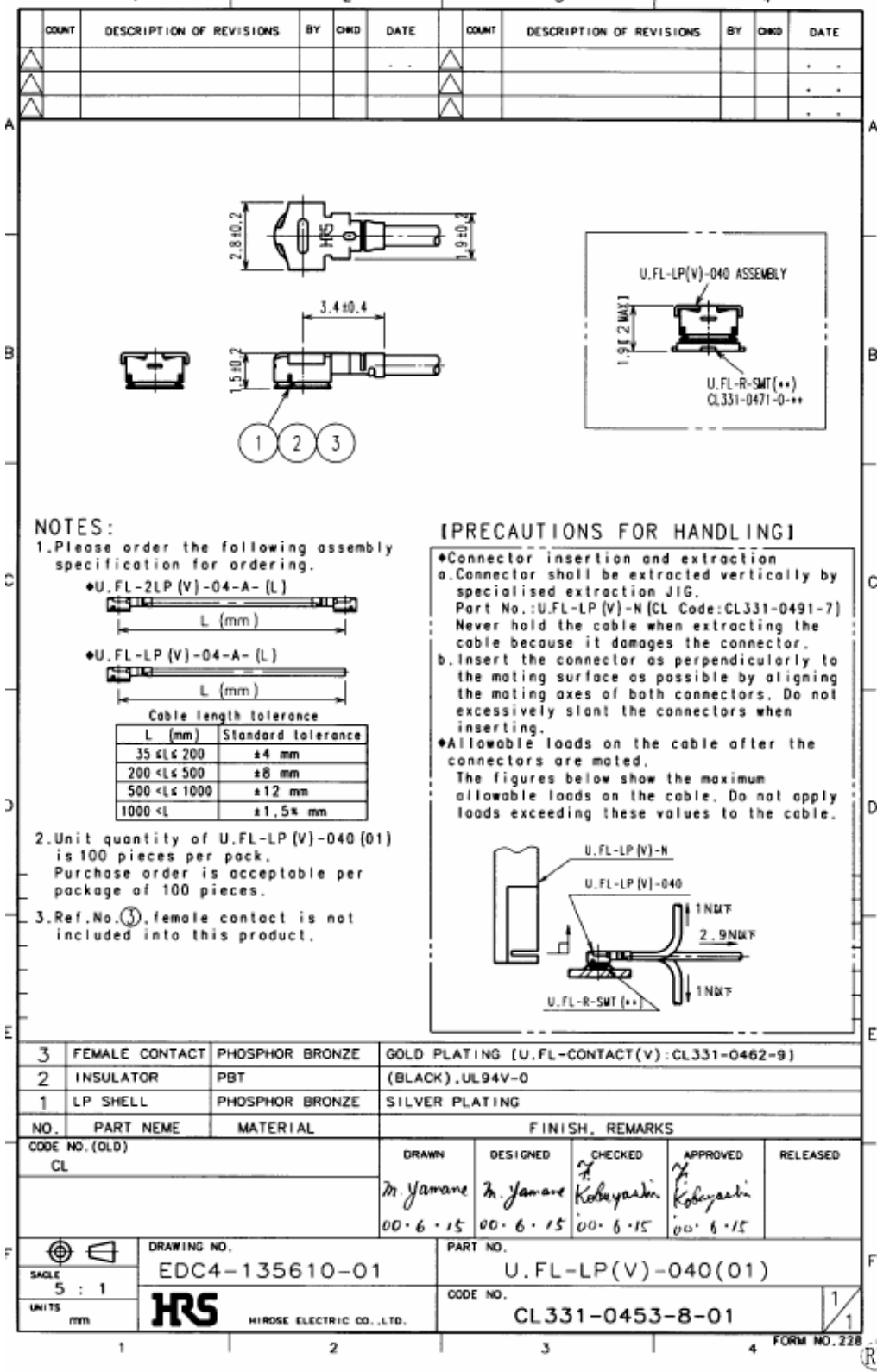

Figure 31: Specifications of U.FL-LP-(V)-040(01) plug

Table 25: Ordering information for Hirose U.FL Series

Item	Part number	HRS number
Connector on MC55i	U.FL-R-SMT	CL331-0471-0-10
Right-angle plug shell for Ø 0.81 mm cable	U.FL-LP-040	CL331-0451-2
Right-angle plug for Ø 0.81 mm cable	U.FL-LP(V)-040 (01)	CL331-053-8-01
Right-angle plug for Ø 1.13 mm cable	U.FL-LP-066	CL331-0452-5
Right-angle plug for Ø 1.32 mm cable	U.FL-LP-066	CL331-0452-5
Extraction jig	E.FL-LP-N	CL331-0441-9

5 Electrical, Reliability and Radio Characteristics

5.1 Absolute Maximum Ratings

Absolute maximum ratings for supply voltage and voltages on digital and analog pins of MC55i are listed in [Table 26](#). Exceeding these values will cause permanent damage to MC55i.

Table 26: Absolute maximum ratings

Parameter	Min	Max	Unit
Voltage BATT+	-0.3	5.5	V
Voltage at digital pins	-0.3	3.3	V
Voltage at analog pins	-0.3	3.0	V
Voltage at digital / analog pins in POWER DOWN mode	-0.25	+0.25	V
Voltage at POWER pin		12	V
Voltage at CHARGE pin		12	V
Differential load resistance between EPNx and EPPx	15		Ω

5.2 Operating Temperatures

Please note that the module's lifetime, i.e., the MTTF (mean time to failure) may be reduced, if operated outside the restricted temperature range. A special URC reports whether the module enters or leaves the restricted temperature range (see [1]; AT^SCTM).

Table 27: Board / battery temperature

Parameter	Min	Typ	Max	Unit
Normal operation	-20	+25	+70	°C
Automatic shutdown ^{1 2}				
Temperature measured on MC55i board	-40	---	>+80	°C
Temperature measured at battery NTC	-18	---	+60	°C

¹. When an emergency call is in progress automatic thermal shutdown is deferred. See also [Section 3.3.3.2](#)

². Due to temperature measurement uncertainty, a tolerance of $\pm 3^{\circ}\text{C}$ on the thresholds may occur.

Table 28: Ambient temperature according to IEC 60068-2 (without forced air circulation)

Parameter	Min	Typ	Max	Unit
Normal operation	-20	+25	+55	°C
Restricted operation ¹				
Restricted temperature range	-40 to -20	---	+55 to +70	°C

¹. Restricted operation according to 3GPP TS 45.005 V6.7.0 (2004-11), Annex D, D.2.1, Temperature (GSM 400, GSM 900 and DCS 1 800): "Outside this temperature range the MS, if powered on, shall not make ineffective use of the radio frequency spectrum. In no case shall the MS exceed the transmitted levels as defined in 3GPP TS 45.005 for extreme operation."

Table 29: Charging temperature

Parameter	Min	Typ	Max	Unit
Battery temperature for software controlled fast charging (measured at battery NTC)	0	---	+45	°C

See also [Section 3.3.3.1](#) for information about the NTCs for on-board and battery temperature measurement, automatic thermal shutdown and alert messages.

Note that within the specified operating temperature ranges the board temperature may vary to a great extent depending on operating mode, used frequency band, radio output power and current supply voltage.

When data are transmitted over GPRS the MC55i automatically reverts to a lower Multislot Class if the temperature rises to the limit specified for normal operation and, vice versa, returns to the higher Multislot Class if the temperature is back to normal. For details see [Section 3.4](#).

The automatic shutdown threshold $T_{\text{amb max}} = +70^{\circ}\text{C}$ applies to PCL5 (GSM 900 / GSM 850), GPRS Class 8 operating mode (1Tx, 4Rx) and a supply voltage not higher than 4.2V. To achieve the upper limit $T_{\text{amb max}} = +70^{\circ}\text{C}$ at permanent GPRS class 8 operation with 4.2V supply voltage it is recommended to integrate MC55i in such a way that a minor heat exchange with the environment can take place. A solution might be the usage of a small heat sink.

5.3 Storage Conditions

The conditions stated below are only valid for modules in their original packed state in weather protected, non-temperature-controlled storage locations. Normal storage time under these conditions is 12 months maximum.

Table 30: Storage conditions

Type	Condition	Unit	Reference
Air temperature: Low High	-40 +85	°C	ETS 300 019-2-1: T1.2, IEC 68-2-1 Ab ETS 300 019-2-1: T1.2, IEC 68-2-2 Bb
Humidity relative: Low High Condens.	10 90 at 30°C 90-100 at 30°C	%	--- ETS 300 019-2-1: T1.2, IEC 68-2-56 Cb ETS 300 019-2-1: T1.2, IEC 68-2-30 Db
Air pressure: Low High	70 106	kPa	IEC TR 60271-3-1: 1K4 IEC TR 60271-3-1: 1K4
Movement of surrounding air	1.0	m/s	IEC TR 60271-3-1: 1K4
Water: rain, dripping, icing and frosting	Not allowed	---	---
Radiation: Solar Heat	1120 600	W/m ²	ETS 300 019-2-1: T1.2, IEC 68-2-2 Bb ETS 300 019-2-1: T1.2, IEC 68-2-2 Bb
Chemically active substances	Not recommended		IEC TR 60271-3-1: 1C1L
Mechanically active substances	Not recommended		IEC TR 60271-3-1: 1S1
Vibration sinusoidal: Displacement Acceleration Frequency range	1.5 5 2-9 9-200	mm m/s ² Hz	IEC TR 60271-3-1: 1M2
Shocks: Shock spectrum Duration Acceleration	semi-sinusoidal 1 50	ms m/s ²	IEC 68-2-27 Ea

5.4 Reliability Characteristics

The test conditions stated below are an extract of the complete test specifications.

Table 31: Summary of reliability test conditions

Type of test	Conditions	Standard
Vibration	Frequency range: 10-20 Hz; acceleration: 3.1mm amplitude Frequency range: 20-500 Hz; acceleration: 5g Duration: 2h per axis = 10 cycles; 3 axes	DIN IEC 68-2-6
Shock half-sinus	Acceleration: 500g Shock duration: 1msec 1 shock per axis 6 positions (\pm x, y and z)	DIN IEC 68-2-27
Dry heat	Temperature: $+70 \pm 2^{\circ}\text{C}$ Test duration: 16 h Humidity in the test chamber: $< 50\%$	EN 60068-2-2 Bb ETS 300019-2-7
Temperature change (shock)	Low temperature: $-40^{\circ}\text{C} \pm 2^{\circ}\text{C}$ High temperature: $+85^{\circ}\text{C} \pm 2^{\circ}\text{C}$ Changeover time: $< 30\text{s}$ (dual chamber system) Test duration: 1 h Number of repetitions: 100	DIN IEC 68-2-14 Na ETS 300019-2-7
Damp heat cyclic	High temperature: $+55^{\circ}\text{C} \pm 2^{\circ}\text{C}$ Low temperature: $+25^{\circ}\text{C} \pm 2^{\circ}\text{C}$ Humidity: $93\% \pm 3\%$ Number of repetitions: 6 Test duration: 12h + 12h	DIN IEC 68-2-30 Db ETS 300019-2-5
Cold (constant exposure)	Temperature: $-40 \pm 2^{\circ}\text{C}$ Test duration: 16 h	DIN IEC 68-2-1

5.5 Electrical Specifications of the Application Interface

Please note that the reference voltages listed in [Table 32](#) are the values measured directly on the MC55i module. They do not apply to the accessories connected.

If an input pin is specified for $V_{i,h,max} = 3.3V$, be sure never to exceed the stated voltage. The value 3.3V is an absolute maximum rating.

The Hirose DF12C board-to-board connector on MC55i is a 50-pin double-row receptacle. The names and the positions of the pins can be seen from [Figure 34](#) which shows the top view of MC55i.

1	CCCLK	EPN2	50
2	CCVCC	EPP2	49
3	CCIO	EPP1	48
4	CCRST	EPN1	47
5	CCIN	MICN2	46
6	CCGND	MICP2	45
7	RXDDAI	MICP1	44
8	TFSDAI	MICN1	43
9	SCLK	AGND	42
10	TXDDAI	IGT	41
11	RFSDAI	EMERGOFF	40
12	BATT_TEMP	DCD0	39
13	SYNC	CTS1	38
14	RXD1	CTS0	37
15	RXD0	RTS1	36
16	TXD1	DTR0	35
17	TXD0	RTS0	34
18	VDDL	DSR0	33
19	POWER	RING0	32
20	CHARGE	VDD	31
21	GND	BATT+	30
22	GND	BATT+	29
23	GND	BATT+	28
24	GND	BATT+	27
25	GND	BATT+	26

Figure 32: Pin assignment

Table 32: Electrical description of application interface

Function	Signal name	IO	Signal form and level	Comments
Power supply	BATT+	I	$V_I = 3.3V$ to $4.8V$ $V_{I\text{norm}} = 4.2V$ $I_{\text{norm}} \approx 1.6A$ during Tx burst	Power supply input. 5 BATT+ pins to be connected in parallel. 5 GND pins to be connected in parallel. The power supply must be able to meet the requirements of current consumption in a Tx burst (up to 2A). Sending with two timeslots doubles the duration of current pulses to $1154\mu s$ (every $4.616ms$).
	GND		 <p>1 Tx, peak current $577\mu s$ every $4.616ms$ 2 Tx, peak current $1154\mu s$ every $4.616ms$</p>	
Charge interface	POWER	I	$V_{I\text{min}} = 3.5V$ $V_{I\text{max}} = 12V$	This line signals to the processor that the charger is connected. Note: The POWER line requires a $10\text{-}47nF$ EMC capacitor, connected to ground (e.g. Pin 21) and placed as close as possible to the module's B2B connector. Note: The module cannot be switched off as long as POWER remains high. It is therefore recommended to disconnect the charger before switching off the module. If unused keep pin open.
	BATT_TEMP	I	Connect NTC with $R_{NTC} \approx 10k\Omega @ 25^\circ C$ to ground.	Input to measure the battery temperature over NTC resistor. NTC should be installed inside or near battery pack to enable the charging algorithm and deliver temperature values. If unused keep pin open.
	CHARGE	O	$I_{\text{CHARGEmax}} = 2mA$ $V_{IH\text{max}} = 12V$ $V_{LO\text{max}} = 0.25V$ at $I = 2mA$	This line is a current source for the charge FET with a $10k\Omega$ resistance between gate and source. If unused keep pin open.

Table 32: Electrical description of application interface

Function	Signal name	IO	Signal form and level	Comments
External supply voltage	VDD	O	VDDmin = 2.75V, VDDtyp = 2.85V, VDDmax = 2.95V I _{max} = -10mA C _L max = 1µF	Supply voltage, e.g. for an external LED or level shifter. The external digital logic must not cause any spikes or glitches on voltage VDD. Not available in POWER DOWN mode. VDD signalises the “ON” state of the module. If unused VDD keep pin open.
VDD Low Power	VDDL	I/O	R _I = 1kΩ V _O max ≈ 4.3V (output) V _I min = 2.2V, V _I max = 5.5V (input) I _I typ = 10µA at BATT+ = 0V Mobile in POWER DOWN mode: V _I min = 1.2V	Supplies the RTC with power via an external capacitor or buffer battery if no V _{BATT+} is applied. If unused keep pin open.
Ignition	IGT	I	R _I ≈ 100kΩ, C _I ≈ 1nF V _{IL} max = (BATT+) -0.5V at I = -5µA V _{IL} min = 0V at I _{max} = -50µA V _{Open} max = 4.8V ON  Active Low ≥ 100ms	Input to switch the mobile ON. The line must be driven low by an Open Drain or Open Collector driver.
Emergency shutdown	EMERGOFF	I/O	R _I ≈ 100kΩ V _{IL} max = 0.3V at I _{max} = -500µA V _{Open} max = 2.82V Signal  Active Low ≥ 10ms	Signal is always high. This line must be driven by an Open Drain or Open Collector driver. Emergency shutdown deactivates the power supply to the module. The module can be reset if IGT is activated after emergency shutdown. To switch the mobile off use the AT^SMSO command. If unused keep pin open.

Table 32: Electrical description of application interface

Function	Signal name	IO	Signal form and level	Comments
Synchroni- zation	SYNC	O	$V_{OL} \text{ max} = 0.2\text{V}$ at $I = 1\text{mA}$ $V_{OH} \text{ min} = 2.35\text{V}$ at $I = -1\text{mA}$ $V_{OH} \text{ max} = 2.73\text{V}$  1 Tx, 877µs impulse each 4.616ms and 2 Tx, 1454µs impulse each 4.616ms, with 300µs forward time.	Indicates increased current consumption during uplink transmission burst. Note that timing is different during hand-over. Alternatively used to control status LED (see Section 3.13.2.2). If unused keep pin open.
3V SIM interface	CCIN	I	$R_I \approx 100\text{k}\Omega$ $V_{IL} \text{ max} = 0.5\text{V}$ $V_{IH} \text{ min} = 2.15\text{V}$ at $I = 20\mu\text{A}$, $V_{IH} \text{ max} = 3.3\text{V}$ at $I = 30\mu\text{A}$	CCIN = high, SIM card holder closed (no card recognition) Maximum cable length 200mm to SIM card holder. All signals of SIM interface are protected against ESD with a special diode array. Usage of CCGND is mandatory.
	CCRST	O	$R_O \approx 47\Omega$ $V_{OL} \text{ max} = 0.25\text{V}$ at $I = 1\text{mA}$ $V_{OH} \text{ min} = 2.5\text{V}$ at $I = -1\text{mA}$ $V_{OH} \text{ max} = 2.95\text{V}$	
	CCIO	I/O	$R_I \approx 4.7\text{k}\Omega$ $V_{IL} \text{ max} = 0.5\text{V}$ $V_{IH} \text{ min} = 2.00\text{V}$, $V_{IH} \text{ max} = 3.3\text{V}$ $R_O \approx 100\Omega$ $V_{OL} \text{ max} = 0.3\text{V}$ at $I = 1\text{mA}$ $V_{OH} \text{ min} = 2.65\text{V}$ at $I = -20\mu\text{A}$ $V_{OH} \text{ max} = 2.95\text{V}$	
	CCCLK	O	$R_O \approx 100\Omega$ $V_{OL} \text{ max} = 0.3\text{V}$ at $I = 1\text{mA}$ $V_{OH} \text{ min} = 2.45\text{V}$ at $I = -1\text{mA}$ $V_{OH} \text{ max} = 2.95\text{V}$	
	CCVCC	O	$R_O \text{ max} = 5\Omega$ $\text{CCVCC min} = 2.75\text{V}$, $\text{CCVCC max} = 2.95\text{V}$ $I \text{ max} = -20\text{mA}$	
	CCGND		Ground	

Table 32: Electrical description of application interface

Function	Signal name	IO	Signal form and level	Comments
1.8V SIM interface	CCIN	I	$R_I \approx 100k\Omega$ $V_{ILmax} = 0.3V$ $V_{IHmin} = 1.40V$ at $I = 15\mu A$, $V_{IHmax} = 3.3V$ at $I = 30\mu A$	<p>CCIN = high, SIM card holder closed (no card recognition)</p> <p>Maximum cable length 200mm to SIM card holder.</p> <p>All signals of SIM interface are protected against ESD with a special diode array.</p> <p>Usage of CCGND is mandatory.</p>
	CCRST	O	$R_O \approx 47\Omega$ $V_{OLmax} = 0.25V$ at $I = 1mA$ $V_{OHmin} = 1.4V$ at $I = -1mA$ $V_{OHmax} = 1.95V$	
	CCIO	I/O	$R_I \approx 4.7k\Omega$ $V_{ILmax} = 0.3V$ $V_{IHmin} = 1.20V$, $V_{IHmax} = 3.3V$ $R_O \approx 100\Omega$ $V_{OLmax} = 0.3V$ at $I = 1mA$ $V_{OHmin} = 1.60V$ at $I = -20\mu A$ $V_{OHmax} = 1.95V$	
	CCCLK	O	$R_O \approx 100\Omega$ $V_{OLmax} = 0.3V$ at $I = 1mA$ $V_{OHmin} = 1.40V$ at $I = -1mA$ $V_{OHmax} = 1.95V$	
	CCVCC	O	$R_{Omax} = 5\Omega$ CCVCCmin = 1.71V, CCVCCmax = 1.95V Imax = 20mA	
	CCGND		Ground	
ASC0 interface	RXD0	O	$V_{OLmax} = 0.2V$ at $I = 1mA$ $V_{OHmin} = 2.40V$ at $I = -1mA$ $V_{OHmax} = 2.82V$ $V_{ILmax} = 0.5V$ $V_{IHmin} = 2.00V$, $V_{IHmax} = 3.3V$ TXD0, RTS0: pull up -15 μA at 0V DTR0: pull up -60 μA at 0V	<p>First serial interface for AT commands or data stream.</p> <p>To avoid floating if output pins are high-impedance, use pull-up resistors tied to VDD or pull-down resistors tied to GND. See Section 3.3.2.1.</p> <p>If unused keep pins open.</p>
	TXD0	I		
	CTS0	O		
	RTS0	I		
	DTR0	I		
	DCD0	O		
	DSR0	O		
	RING0	O		

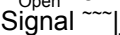
Table 32: Electrical description of application interface

Function	Signal name	IO	Signal form and level	Comments
ASC1 interface	RXD1	O	$V_{OL} \text{ max} = 0.2\text{V}$ at $I = 1\text{mA}$ $V_{OH} \text{ min} = 2.40\text{V}$ at $I = -1\text{mA}$ $V_{OH} \text{ max} = 2.82\text{V}$ $V_{IL} \text{ max} = 0.5\text{V}$ $V_{IH} \text{ min} = 2.00\text{V}$, $V_{IH} \text{ max} = 3.3\text{V}$ TXD0, RTS0: pull up $-60\mu\text{A}$ at 0V	Second serial interface for AT commands. To avoid floating if output pins are high-impedance, use pull-up resistors tied to VDD or pull-down resistors tied to GND. See Section 3.3.2.1 . If unused keep pins open.
	TXD1	I		
	CTS1	O		
	RTS1	I		
Digital audio interface	SCLK	O	$V_{OL} \text{ max} = 0.2\text{V}$ at $I = 1\text{mA}$ $V_{OH} \text{ min} = 2.40\text{V}$ at $I = -1\text{mA}$ $V_{OH} \text{ max} = 2.82\text{V}$ $V_{IL} \text{ max} = 0.5\text{V}$ $V_{IH} \text{ min} = 2.00\text{V}$, $V_{IH} \text{ max} = 3.3\text{V}$ RFSDAI, RXDDAI, SCLK: pull down $+330\mu\text{A}$ at $V_{IN} = 3.3\text{V}$	If unused keep pins open.
	TFSDAI	O		
	TXDDAI	O		
	RXDDAI	I		
	RFSDAI	I		Reserved for future use.

Table 32: Electrical description of application interface

Function	Signal name	IO	Signal form and level	Comments
Analog audio interfaces	EPP2	O	$V_{Omax} = 3.7V_{pp}$ See also Table 36 .	The audio output is balanced and can directly operate an earpiece. If unused keep pins open.
	EPN2	O		
	EPP1	O	$V_{Omax} = 3.7V_{pp}$ See also Table 36 .	Balanced audio output. Can be used to directly operate an earpiece. If unused keep pins open.
	EPN1	O		
	MICP1	I	$R_I \approx 50k\Omega$ differential $V_{Imax} = 1.03V_{pp}$ See also Table 37 .	Balanced microphone input. To be decoupled with 2 capacitors ($C_K = 100nF$), if connected to a microphone or another device. If unused keep pins open.
	MICN1			
	MICP2	I	$R_I = 2k\Omega$ differential $V_{Imax} = 1.03V_{pp}$ See also Table 37 .	Balanced microphone input. Can be used to directly feed an active microphone. If used for another signal source, e.g. op amp, to be decoupled with capacitors. If unused keep pins open.
	MICN2	I		
AGND			Separate ground connection for external audio circuits.	

5.6 Power Supply Ratings

Table 33: Power supply ratings

Parameter	Description	Conditions	Min	Typ	Max	Unit	
BATT+	Supply voltage	Voltage must stay within the min/ max values, including voltage drop, ripple and spikes.	3.3	4.2	4.8	V	
	Voltage drop during transmit burst	Normal condition, power control level for P _{out max}			400	mV	
	Voltage ripple	Normal condition, power control level for P _{out max} @ f<200kHz @ f>200kHz		50 2		mV	
I _{BATT+}	Average supply current ¹	POWER DOWN mode		50	100	µA	
		SLEEP mode @ DRX = 2 @ DRX = 5 @ DRX = 9		4.3 3.0 2.5		mA	
		IDLE mode @ DRX = 2 GSM 850 EGSM 900 GSM 1800/1900		15 15 15		mA	
		TALK mode GSM850 ^{2 3} EGSM 900 ^{2 3} GSM 1800/1900 ^{4 3}		260 260 180	310	mA	
		DATA mode GPRS (4 Rx, 1 Tx) GSM 850 ^{2 3} EGSM 900 ^{2 3} GSM 1800/1900 ^{4 3}		300 300 230		mA	
		DATA mode GPRS (3 Rx, 2 Tx) GSM 850 ^{2 3} EGSM 900 ^{2 3} GSM 1800/1900 ^{4 3}		450 450 330	550	mA	
		Peak supply current (during transmission slot every 4.6ms)	Power Control Level ²		1.6	2.0	A

1. All average supply current values @ IVDD = 0mA
2. Power control level PCL 5
3. Test conditions for the typical values: 50Ω antenna
4. Power control level PCL 0

5.7 Electrical Characteristics of the Voiceband Part

5.7.1 Setting Audio Parameters by AT Commands

The audio modes 2 to 6 can be adjusted according to the parameters listed below. Each audio mode is assigned a separate set of parameters.

Table 34: Audio parameters adjustable by AT command

Parameter	Influence to	Range	Gain range	Calculation
inBbcGain	MICP/MICN analog amplifier gain of baseband controller before ADC	0...7	0...42dB	6dB steps
inCalibrate	Digital attenuation of input signal after ADC	0...32767	$-\infty$...0dB	$20 * \log(\text{inCalibrate}/32768)$
outBbcGain	EPP/EPN analog output gain of baseband controller after DAC	0...3	0...-18dB	6dB steps
outCalibrate[n] n = 0...4	Digital attenuation of output signal after speech decoder, before summation of sidetone and DAC present for each volume step[n]	0...32767	$-\infty$...+6dB	$20 * \log(2 * \text{outCalibrate}[n]/32768)$
sideTone	Digital attenuation of sidetone is corrected internally by outBbcGain to obtain a constant sidetone independent of output volume	0...32767	$-\infty$...0dB	$20 * \log(\text{sideTone}/32768)$

Note: The parameters inCalibrate, outCalibrate and sideTone accept also values from 32768 to 65535. These values are internally truncated to 32767.

5.7.2 Audio Programming Model

The audio programming model shows how the signal path can be influenced by varying the AT command parameters. The model is the same for all three interfaces, except for the parameters `<outBbcGain>` and `<inBbcGain>` which cannot be modified if the digital audio interface is being used, since in this case the DAC is switched off.

The parameters `<inBbcGain>` and `<inCalibrate>` can be set with `AT^SNFI`. All the other parameters are adjusted with `AT^SNFO` and `AT^SAIC`.

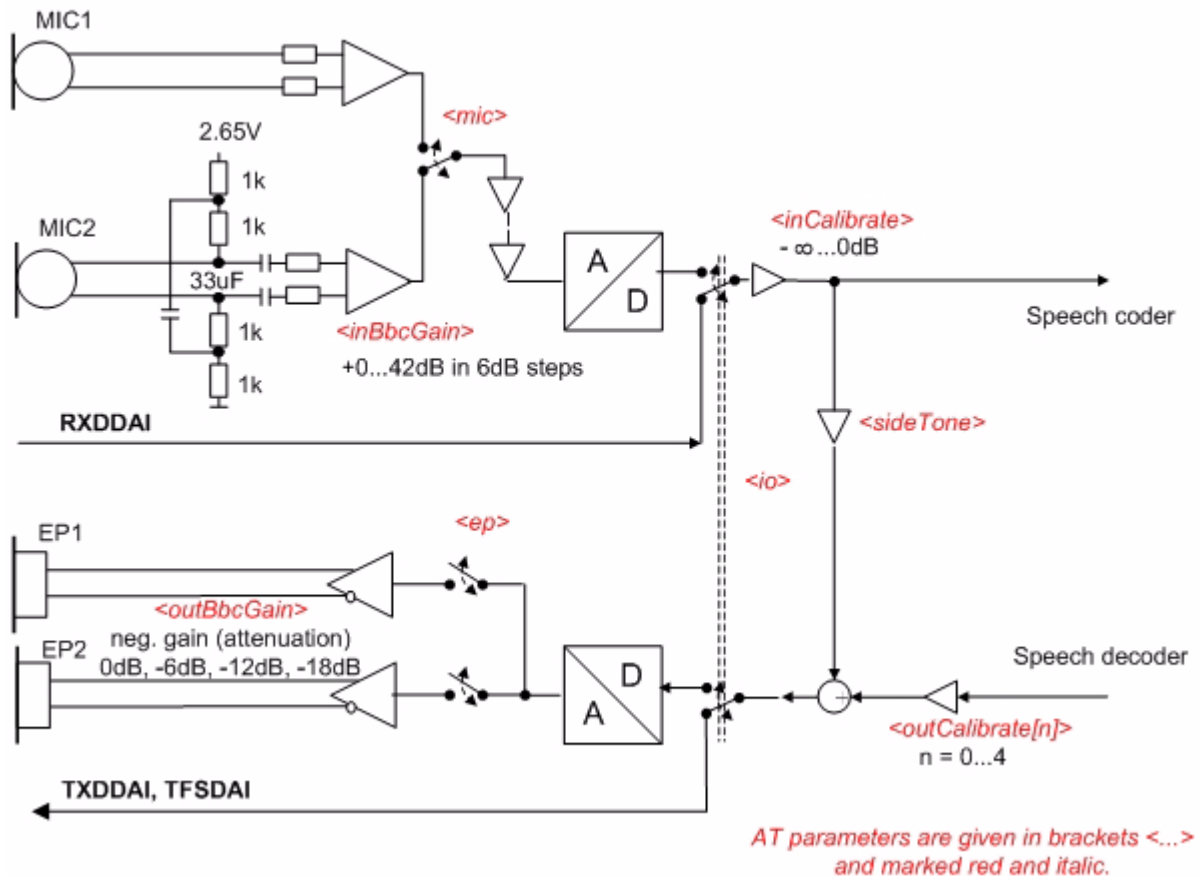

Figure 33: Audio programming model

5.7.3 Characteristics of Audio Modes

The electrical characteristics of the voiceband part depend on the current audio mode set with the AT[^]SNFS command.

Table 35: Voiceband characteristics (typical)

Audio mode no. AT [^] SNFS=	1 (Default settings, not adjustable)	2	3	4	5	6
Name	Default Handset	Basic Handsfree	Headset	User Handset	Plain Codec 1	Plain Codec 2
Purpose	DSB with Votronic handset	Car Kit	Headset	DSB with individual handset	Direct access to speech coder	Direct access to speech coder
Gain setting via AT command. Defaults: inBbcGain outBbcGain	Fix 4 (24dB) 0 (6dB)	Adjustable 2 (12dB) 2(-12dB)	Adjustable 6(36dB) 2(-12dB)	Adjustable 4 (24dB) 0 (0dB)	Adjustable 0 (0dB) 0 (0dB)	Adjustable 0 (0dB) 0 (0dB)
Default audio interface	1	2	2	1	1	2 ¹
Power supply	ON (2.65V)	ON (2.65V)	ON (2.65V)	ON (2.65V)	ON (2.65V)	ON (2.65V)
Sidetone	ON	---	Adjustable	Adjustable	Adjustable	Adjustable
Volume control	OFF	Adjustable	Adjustable	Adjustable	Adjustable	Adjustable
Echo control (send)	Cancellation	Cancellation	Cancellation	Cancellation	---	---
Noise suppression ²	---	15dB	15dB	---	---	---
MIC input signal for 0dBm0 @ 1024 Hz (default gain)	18mV	65mV	7.5mV	18mV	315mV	315mV
EP output signal in mV rms. @ 0dBm0, 1024 Hz, no load (default gain); @ 3.14 dBm0	620mV	210mV default @ max volume	320mV default @ max volume	620mV default @ max volume	880mV 3.7Vpp	880mV 3.7Vpp
Sidetone gain at default settings	21.5dB	-∞ dB	20.5dB	21.5dB	-3dB @ sidetone = 8192 ³	-3dB @ sidetone = 8192 ³

- ¹. Audio mode 5 and 6 are identical. With AT[^]SAIC, you can easily switch mode 5 to the second interface. Therefore, audio mode 6 is only kept for compatibility to earlier Cinterion Wireless Modules GSM products.
- ². In audio modes with noise reduction, the microphone input signal for 0dBm0 shall be measured with a sine burst signal for a tone duration of 5 seconds and a pause of 2 sec. The sine signal appears as noise and, after approx. 12 sec, is attenuated by the noise reduction by up to 10dB.
- ³. See AT[^]SNFO command.

Note: With regard to acoustic shock, the cellular application must be designed to avoid sending false AT commands that might increase amplification, e.g. for a high sensitive earpiece. A protection circuit should be implemented in the cellular application.

5.7.4 Voiceband Receive Path

Test conditions:

- The values specified below were tested to 1kHz and 0dB gain stage, unless otherwise stated.
- Parameter setup: gs = 0dB means audio mode = 5 for EPP1 to EPN1 and 6 for EPP2 to EPN2, inBbcGain= 0, inCalibrate = 32767, outBbcGain = 0, OutCalibrate = 16384, sideTone = 0.

Table 36: Voiceband receive path

Parameter	Min	Typ	Max	Unit	Test condition / remark
Differential output voltage (peak to peak)	3.3	3.7	4.1	V	from EPPx to EPNx gs = 0dB @ 3.14dBm0 no load
Differential output gain settings (gs) at 6dB stages (outBbcGain)	-18		0	dB	Set with AT^SNFO
Fine scaling by DSP (outCalibrate)	-∞		0	dB	Set with AT^SNFO
Output differential DC offset			+/-50	mV	gs = 0dB, outBbcGain = 0 and -6dB
Differential output resistance		4		Ω	from EPP1 to EPN1
Differential output resistance		2		Ω	from EPP2 to EPN2
Allowed differential load capacitance			100	pF	from EPP1 to EPN1
Allowed differential load capacitance			2000	pF	from EPP2 to EPN2
Absolute gain drift			+/- 2	%	Variation due to change in temperature and life time
Passband ripple			0.5	dB	for f < 3600 Hz
Stopband attenuation	50			dB	for f > 4600 Hz

gs = gain setting

5.7.5 Voiceband Transmit Path

Test conditions:

- The values specified below were tested to 1kHz and 0dB gain stage, unless otherwise stated.
- Parameter setup: Audio mode = 5 for MICP1 to MICN1 and 6 for MICP2 to MICN2, inBbcGain = 0, inCalibrate = 32767, outBbcGain = 0, OutCalibrate = 16384, sideTone = 0

Table 37: Voiceband transmit path

Parameter	Min	Typ	Max	Unit	Test condition/Remark
Input voltage (peak to peak) MICP1 to MICN1, MICP2 to MICN2			1.03	V	
Input amplifier gain in 6dB steps (inBbcGain)	0		42	dB	Set with AT^SNFI
Fine scaling by DSP (inCalibrate)	-∞		0	dB	Set with AT^SNFI
Input impedance MIC1		50		kΩ	
Input impedance MIC2		2.0		kΩ	
Microphone supply voltage ON Ri = 4kΩ (MIC2 only)	2.57 2.17 1.77	2.65 2.25 1.85	2.73 2.33 1.93	V V V	no supply current @ 100μA @ 200μA
Microphone supply voltage OFF; Ri = 4kΩ (MIC2 only)		0		V	
Microphone supply in POWER DOWN mode					See Figure 18 .

5.8 Air Interface

Test conditions: All measurements have been performed at $T_{amb} = 25^{\circ}\text{C}$, $V_{BATT+nom} = 4.1\text{V}$.

Table 38: Air Interface

Parameter		Min	Typ	Max	Unit
Frequency range Uplink (MS → BTS)	GSM 850	824		849	MHz
	E-GSM 900	880		915	MHz
	GSM 1800	1710		1785	MHz
	GSM 1900	1850		1910	MHz
Frequency range Downlink (BTS → MS)	GSM 850	869		894	MHz
	E-GSM 900	925		960	MHz
	GSM 1800	1805		1880	MHz
	GSM 1900	1930		1990	MHz
RF power @ ARP with 50Ω load	GSM 850	31	33	35	dBm
	E-GSM 900 ¹	31	33	35	dBm
	GSM 1800 ²	28	30	32	dBm
	GSM 1900	28	30	32	dBm
Number of carriers	GSM 850		124		
	E-GSM 900		174		
	GSM 1800		374		
	GSM 1900		299		
Duplex spacing	GSM 850		45		MHz
	E-GSM 900		45		MHz
	GSM 1800		95		MHz
	GSM 1900		80		MHz
Carrier spacing			200		kHz
Multiplex, Duplex	TDMA / FDMA, FDD				
Time slots per TDMA frame			8		
Frame duration			4.615		ms
Time slot duration			577		μs
Modulation	GMSK				
Receiver input sensitivity @ ARP BER Class II < 2.4% (static input level)	GSM 850	-102 ³	-107 ⁴		dBm
	E-GSM 900	-102 ³	-107 ⁴		dBm
	GSM 1800	-102 ³	-107 ⁴		dBm
	GSM 1900	-102 ³	-107 ⁴		dBm

1. Power control level PCL 5
2. Power control level PCL 0
3. Under fading conditions
4. Typical value is at least -107dBm.

5.9 Electrostatic Discharge

The GSM module is not protected against Electrostatic Discharge (ESD) in general. Consequently, it is subject to ESD handling precautions that typically apply to ESD sensitive components. Proper ESD handling and packaging procedures must be applied throughout the processing, handling and operation of any application that incorporates a MC55i module.

Special ESD protection provided on MC55i:

- SIM interface: Clamp diodes for protection against overvoltage.
- Antenna port: RF choke to ground.
- The remaining ports of MC55i are not accessible to the user of the final product (since they are installed within the device) and therefore, are only protected according to the “Human Body Model” requirements.

MC55i has been tested according to group standard ETSI EN 301 489-1 (see [Table 3](#)) and test standard EN 61000-4-2. The measured values can be gathered from the following table.

Table 39: Measured electrostatic values

Specification / Requirements	Contact discharge	Air discharge
EN 61000-4-2		
SIM interface	± 4kV	± 8kV
Antenna interface	± 4kV	± 8kV
JEDEC JESD22-A114D (Human Body Model, Test conditions: 1.5 kΩ, 100 pF)		
ESD at the module	± 1kV	n.a.

Note: Please note that the values may vary with the individual application design. For example, it matters whether or not the application platform is grounded over external devices like a computer or other equipment, such as the Cinterion Wireless Modules reference application described in [Chapter 7](#).

6 Mechanics

The following sections describe the mechanical dimensions of MC55i and give recommendations for integrating MC55i into the host application.

6.1 Mechanical Dimensions of MC55i

Figure 34 shows the top view on MC55i and provides an overview of the mechanical dimensions of the board. For further details see Figure 35.

Size: $35 \pm 0.15 \times 32.5 \pm 0.15 \times 3.1 \pm 0.3$ mm (including application connector)
 $35 \pm 0.15 \times 32.5 \pm 0.15 \times 2.95 \pm 0.2$ mm (excluding application connector)

Weight: 6g

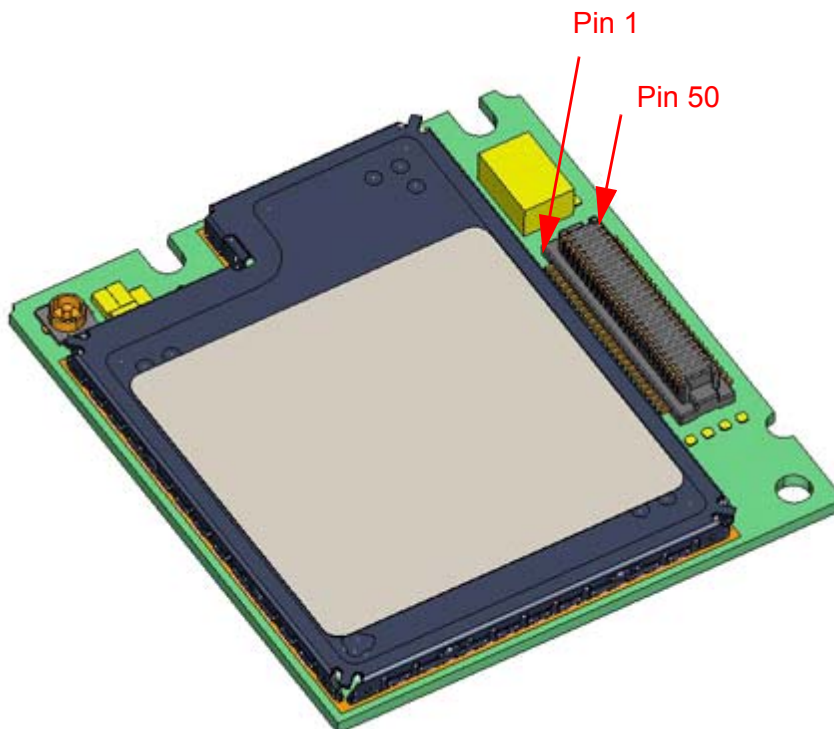

Figure 34: MC55i – top view

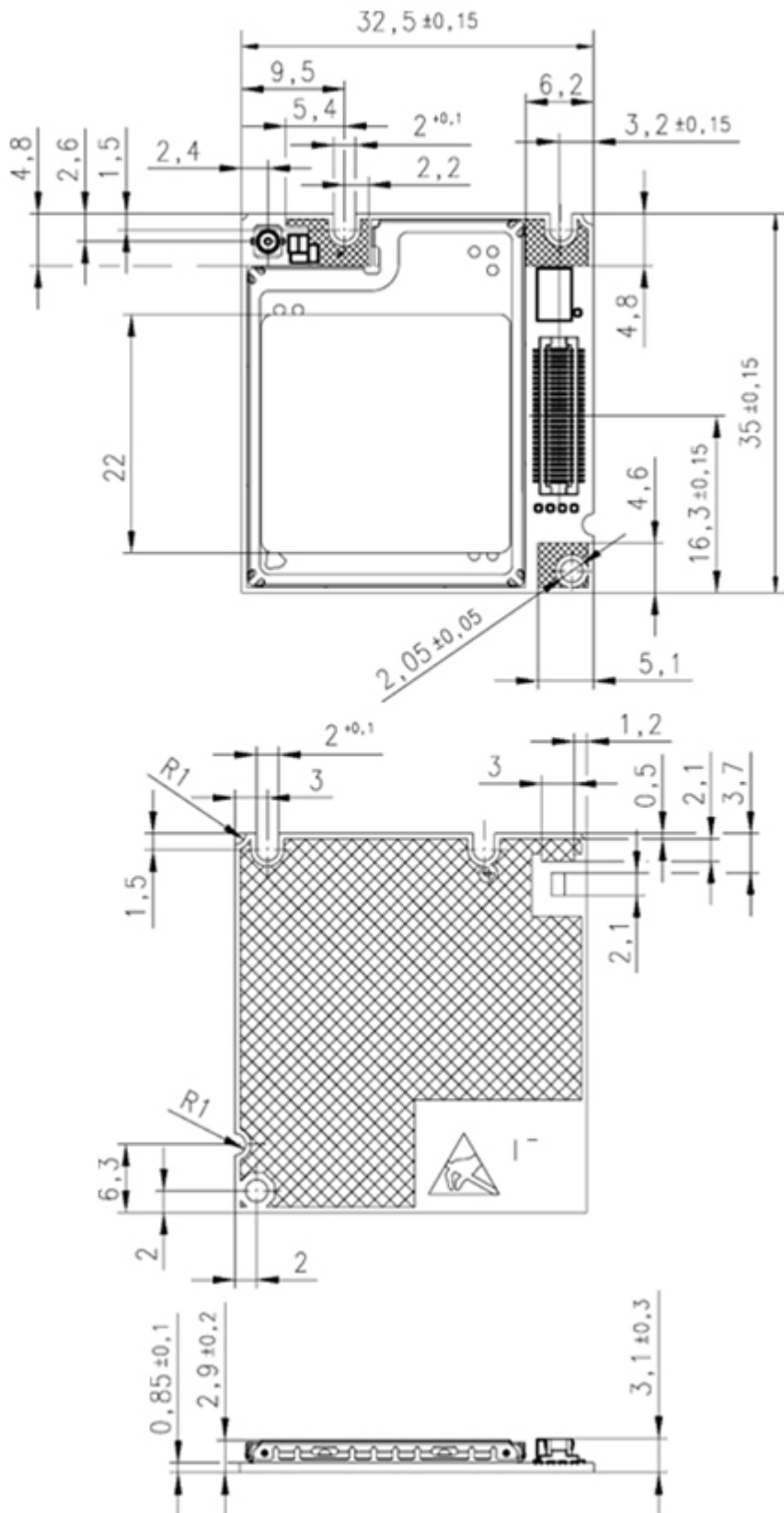

Figure 35: Mechanical dimensions of MC55i (all dimensions in millimeters)

6.2 Mounting MC55i onto the Application Platform

There are many ways to properly install MC55i in the host device. An efficient approach is to mount the MC55i PCB to a frame, plate, rack or chassis.

Fasteners can be M1.6 or M1.8 screws plus suitable washers, circuit board spacers, or customized screws, clamps, or brackets. Screws must be inserted with the screw head on the bottom of the MC55i PCB. In addition, the board-to-board connection can also be utilized to achieve better support.

For proper grounding it is strongly recommended to use the ground plane on the back side in addition to the five GND pins of the board-to-board connector. To avoid short circuits ensure that the remaining sections of the MC55i PCB do not come into contact with the host device.

To prevent mechanical damage, be careful not to force, bend or twist the module. Be sure it is positioned flat against the host device. See also [Section 9.2](#) with mounting advice sheet.

All the information you need to install an antenna is summarized in [Section 4.1](#). Note that the antenna pad on the bottom of the MC55i PCB must not be influenced by any other PCBs, components or by the housing of the host device. It needs to be surrounded by a restricted space as described in [Section 4.1](#).

6.3 Board-to-Board Connector

This section provides specifications for the 50-pin board-to-board connector which serves as physical interface to the host application. The receptacle assembled on the MC55i PCB is type Hirose DF12C. Mating headers from Hirose are available in different stacking heights.



Figure 36: Hirose DF12C receptacle on MC55i

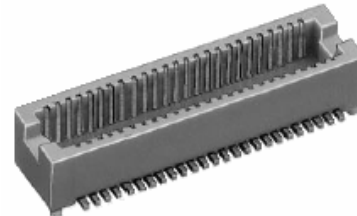

Figure 37: Header Hirose DF12 series

Table 40: Ordering information DF12 series

Item	Part number	Stacking height (mm)	HRS number
Receptacle on MC55i	DF12C(3.0)-50DS-0.5V(81)	3 - 5	537-0694-9-81
Headers DF12 series	DF12E(3.0)-50DP-0.5V(81)	3.0	537-0834-6-**
	DF12E(3.5)-50DP-0.5V(81)	3.5	537-0534-2-**
	DF12E(4.0)-50DP-0.5V(81)	4.0	537-0559-3-**
	DF12E(5.0)-50DP-0.5V(81)	5.0	537-0584-0-**

Note: The headers listed above are without boss and metal fitting. Please contact Hirose for details on other types of mating headers. Asterixed HRS numbers denote different types of packaging.

Table 41: Electrical and mechanical characteristics of the Hirose DF12C connector

Parameter	Specification (50 pin board-to-board connector)
Number of contacts	50
Quantity delivered	2000 connectors per tape & reel
Voltage	50V
Rated current	0.3A max per contact
Resistance	0.05 Ω per contact
Dielectric withstanding voltage	500V RMS min
Operating temperature	-45°C...+125°C
Contact material	phosphor bronze (surface: gold plated)
Insulator material	PA , beige natural
Stacking height	3.0 mm ; 3.5 mm ; 4.0 mm ; 5.0 mm
Insertion force	21.8N
Withdrawal force 1 st	10N
Withdrawal force 50 th	10N
Maximum connection cycles	50

6.3.1 Mechanical Dimensions of the Hirose DF12 Connector

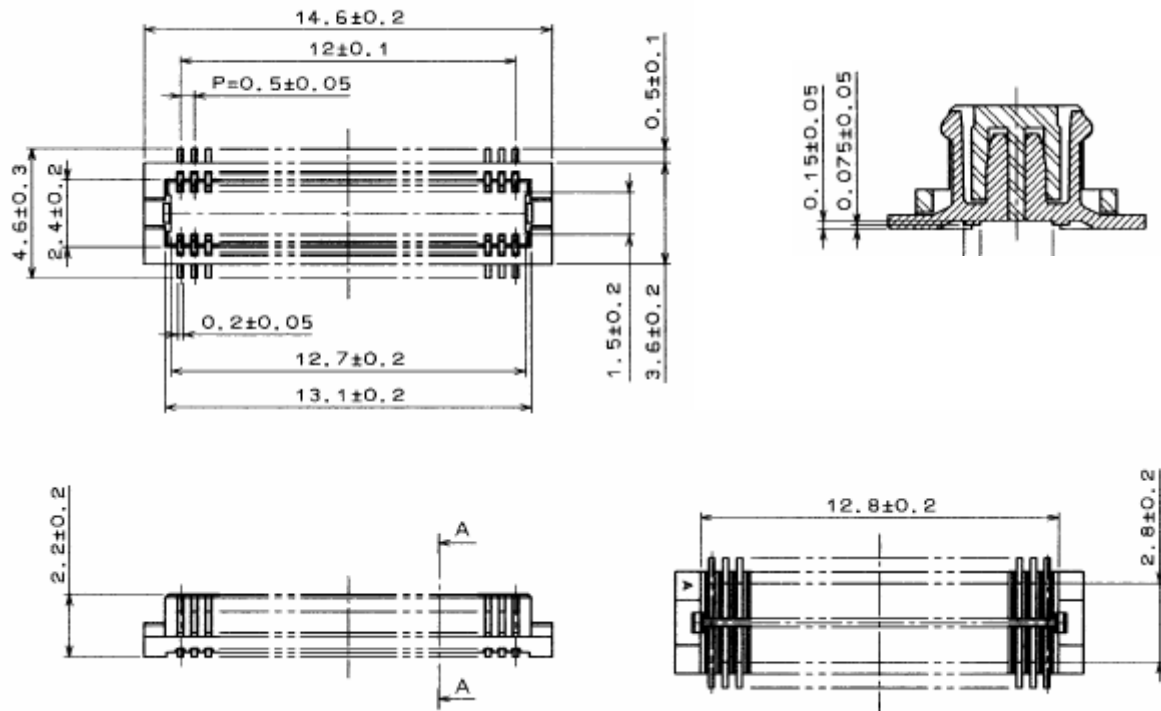

Figure 38: Mechanical dimensions of Hirose DF12 connector

6.3.2 Adapter Cabling

The board-to-board connection is primarily intended for direct contact between both connectors. If this assembly solution does not fit into your application design ensure that the used adapter cable meets the following requirements:

- Maximum length: 200 mm
It is recommended that the total cable length between the board-to-board connector pins on MC55i and the pins of the card holder does not exceed 200 mm in order to meet the specifications of 3GPP TS 51.010-1 and to satisfy the requirements of EMC compliance.
- Type of cable: Flexible cable or flexible printed circuit board designed to mate with the Hirose receptacle and headers specified above.

The equipment submitted for type approving the Cinterion Wireless Modules reference setup of MC55i includes a 160mm adapter cable. See [Section 7.1](#).

7 Reference Approval

7.1 Reference Equipment for Type Approval

The Cinterion Wireless Modules reference setup submitted to type approve MC55i consists of the following components:

- Cinterion Wireless Module MC55i
- Development Support Box (DSB45)
- Flex cable (160 mm) from Hirose DF12C receptacle on MC55i to Hirose DF12 connector on DSB45. Please note that this cable is not included in the scope of delivery of DSB45. As an alternative it is possible to use an adapter board to mount MC55i onto the DSB45 (BACK_PACK_MAJA --> DSB45).
- SIM card reader integrated on DSB45
- Handset type Votronic HH-SI-30.3/V1.1/0
- PC as MMI

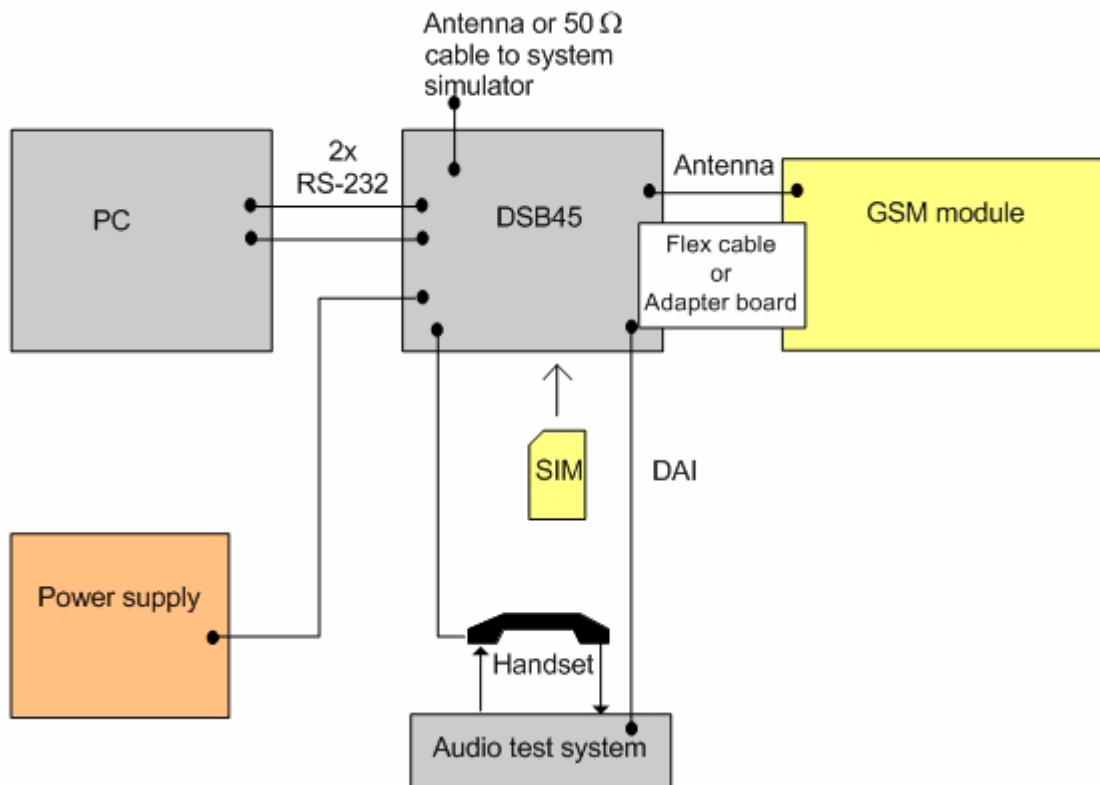

Figure 39: Reference equipment for approval

7.2 Compliance with FCC Rules and Regulations

The Equipment Authorization Certification for the Cinterion Wireless Modules reference application described in [Section 7.1](#) will be registered under the following identifiers:

FCC Identifier: QIPMC55I

Industry Canada Certification Number: 7830A-MC55I

Granted to Cinterion Wireless Modules GmbH

Manufacturers of mobile or fixed devices incorporating MC55i modules are authorized to use the FCC Grants and Industry Canada Certificates of the MC55i modules for their own final products according to the conditions referenced in these documents. In this case, the FCC label of the module shall be visible from the outside, or the host device shall bear a second label stating "Contains FCC ID QIPMC55I", and accordingly "Contains IC 7830A-MC55I".

IMPORTANT:

Manufacturers of portable applications incorporating MC55i modules are required to have their final product certified and apply for their own FCC Grant and Industry Canada Certificate related to the specific portable mobile. This is mandatory to meet the SAR requirements for portable mobiles (see [Section 1.3.2](#) for detail).

Changes or modifications not expressly approved by the party responsible for compliance could void the user's authority to operate the equipment.

8 Sample Application

Figure 40 shows a sample application that incorporates an MC55i module and an external μ Controller. This solution is typical of devices designed for audio and GSM capability, such as mobile phones, PDAs, Tablet PCs etc.

The audio part is made of internal transducers (earpiece and microphone) and integrates an additional interface for connecting an external headset. This interface detects the presence of a plugged headset and verifies whether the headset key (push-to-talk key) is pressed.

The charging circuit is designed to ensure trickle charging that takes effect when the battery is deeply discharged. Used components: 100 Ω series resistance, Z diode 4V3, 1SS355 diode. If the charger supplies a voltage from 5.5V to 8V this arrangement will deliver an overall current of approx. 15mA (5.5V) to 37mA (8V) for trickle charging and for the application. If the application circuit draws a greater current another LDO (Low Dropout Regulator) can be added to allow for an additional parallel power supply dedicated to the application. This LDO can be connected between the positive charger input and the 3V power supply source.

Caution: Trickle charging is done when the voltage of the Li-Ion battery is below 3.2V.

High level of the VDD line indicates that the MC55i module is active.

While MC55i is in POWER DOWN mode the application interface is switched off and must not be fed from any other source. Therefore, the application must be designed to avoid any current flow into any digital pins of the application interface.

The RING0 line notifies, primarily, incoming calls. Therefore, if connected with an interrupt of the application μ Controller, the RING0 line can be effectively used to wake up the application μ Controller from power saving.

The test points (referred to as "TPx") can be used for downloading firmware to the MC55i module.

TP0: GND

TP1: Data transfer from MC55i

TP2: Data transfer to MC55i

TP3: Starts up MC55i (high active)

The EMC measures are best practice recommendations. In fact, an adequate EMC strategy for an individual application is very much determined by the overall layout and, especially, the position of components. For example, mounting the internal acoustic transducers directly on the PCB eliminates the need to use the ferrite beads shown in the sample schematic. The SIM card and the microphone should be positioned as far as possible from the antenna.

Disclaimer

No warranty, either stated or implied, is provided on the sample schematic diagram shown in Figure 40 and the information detailed in this section. As functionality and compliance with national regulations depend to a great amount on the used electronic components and the individual application layout manufacturers are required to ensure adequate design and operating safeguards for their products using MC55i modules.

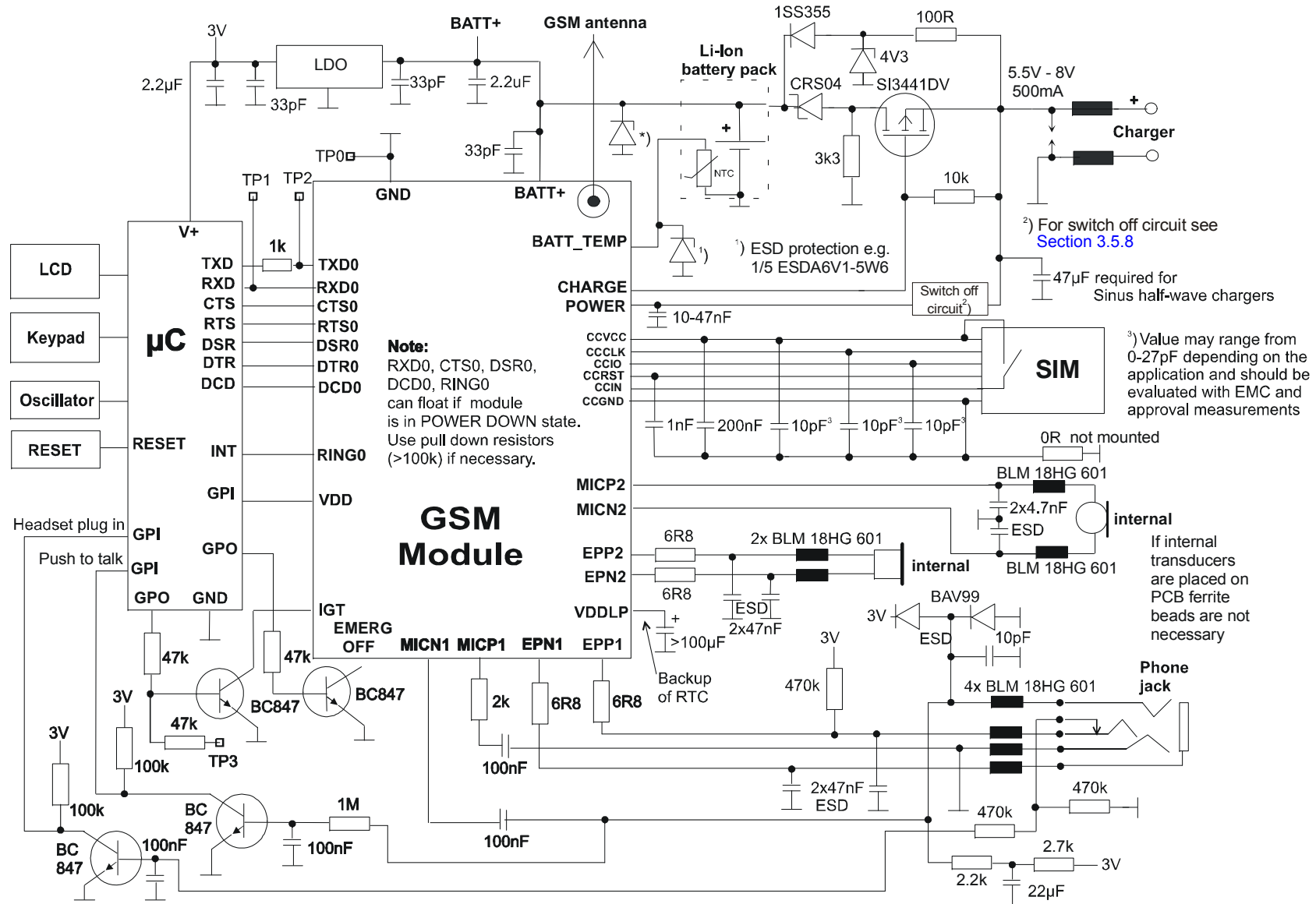

Figure 40: Schematic diagram of MC55i sample application

9 Appendix

9.1 List of Parts and Accessories

Table 42: List of parts and accessories

Description	Supplier	Ordering information
MC55i	Cinterion	Ordering numbers: Cinterion Wireless Modules IMEI: L30960-N1200-D100 Customer IMEI: L30960-N1210-D100
DSB45 Support Box	Cinterion	Ordering number: L36880-N8301-A100
Votronic Handset	VOTRONIC	Votronic HH-SI-30.3/V1.1/0 VOTRONIC Entwicklungs- und Produktionsgesellschaft für elektro- nische Geräte mbH Saarbrücker Str. 8 66386 St. Ingbert Germany Phone: +49-(0)6 89 4 / 92 55-0 Fax: +49-(0)6 89 4 / 92 55-88 Email: contact@votronic.com
SIM card holder incl. push button ejector and slide-in tray	Molex	Ordering numbers: 91228, 91236 Sales contacts are listed in Table 43 .
DF12C board-to-board connector	Hirose	See Section 6.3 for details on receptacle on MC55i and mating headers. Sales contacts are listed in Table 44 .
U.FL-R-SMT antenna con- nector	Hirose	See Section 4.1.2 for details on U.FL-R-SMT connector, mating plugs and cables. Sales contacts are listed in Table 44 .

Table 43: Molex sales contacts (subject to change)

<p>Molex For further information please click: http://www.molex.com</p>	<p>Molex Deutschland GmbH Felix-Wankel-Str. 11 4078 Heilbronn-Biberach Germany Phone: +49-7066-9555 0 Fax: +49-7066-9555 29 Email: mxgermany@molex.com</p>	<p>American Headquarters Lisle, Illinois 60532 U.S.A. Phone: +1-800-78MOLEX Fax: +1-630-969-1352</p>
<p>Molex China Distributors Beijing, Room 1319, Tower B, COFCO Plaza No. 8, Jian Guo Men Nei Street, 100005 Beijing P.R. China Phone: +86-10-6526-9628 Phone: +86-10-6526-972 Phone: +86-10-6526-9731 Fax: +86-10-6526-9730</p>	<p>Molex Singapore Pte. Ltd. Jurong, Singapore Phone: +65-268-6868 Fax: +65-265-6044</p>	<p>Molex Japan Co. Ltd. Yamato, Kanagawa, Japan Phone: +81-462-65-2324 Fax: +81-462-65-2366</p>

Table 44: Hirose sales contacts (subject to change)

<p>Hirose Ltd. For further information please click: http://www.hirose.com</p>	<p>Hirose Electric (U.S.A.) Inc 2688 Westhills Court Simi Valley, CA 93065 U.S.A. Phone: +1-805-522-7958 Fax: +1-805-522-3217</p>	<p>Hirose Electric GmbH Herzog-Carl-Strasse 4 73760 Ostfildern Germany Phone: +49-711-456002-1 Fax: +49-711-456002-299 Email: info@hirose.de</p>
<p>Hirose Electric UK, Ltd Crownhill Business Centre 22 Vincent Avenue, Crownhill Milton Keynes, MK8 OAB Great Britain Phone: +44-1908-305400 Fax: +44-1908-305401</p>	<p>Hirose Electric Co., Ltd. 5-23, Osaki 5 Chome, Shinagawa-Ku Tokyo 141 Japan Phone: +81-03-3491-9741 Fax: +81-03-3493-2933</p>	<p>Hirose Electric Co., Ltd. European Branch First class Building 4F Beechavenue 46 1119PV Schiphol-Rijk Netherlands Phone: +31-20-6557-460 Fax: +31-20-6557-469</p>

9.2 Mounting Advice Sheet

To prevent mechanical damage, be careful not to force, bend or twist the module. Be sure it is positioned flat against the host device (see also [Section 6.2](#)). The advice sheet on the next page shows a number of examples for the kind of bending that may lead to mechanical damage of the module.

Mounting Advice

Do NOT BEND the Module

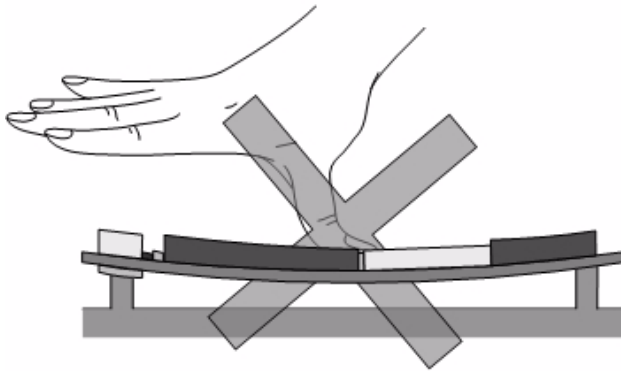

- By pressing from above

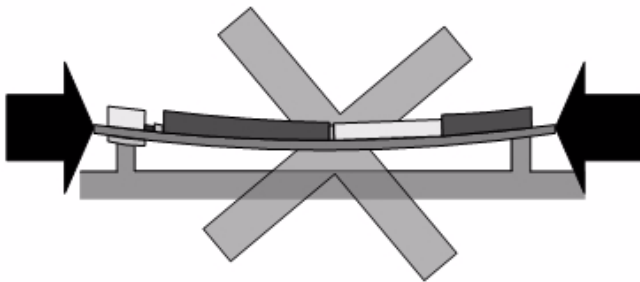

- By mounting under pressure

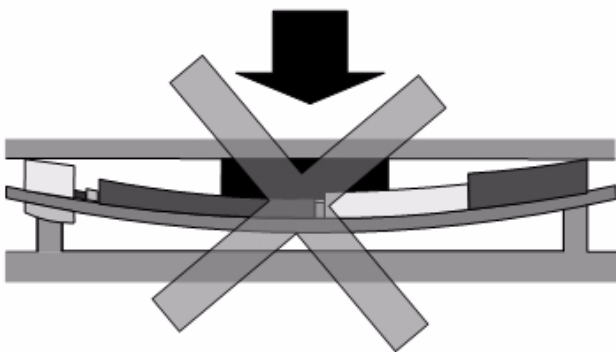

- By putting objects on top

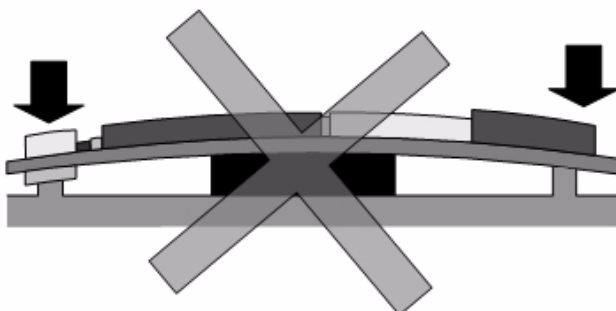

- By putting objects below