

Electronic Circuit Diagram _ K639

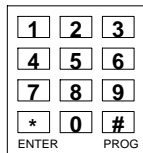

3 x 4 key board lay out

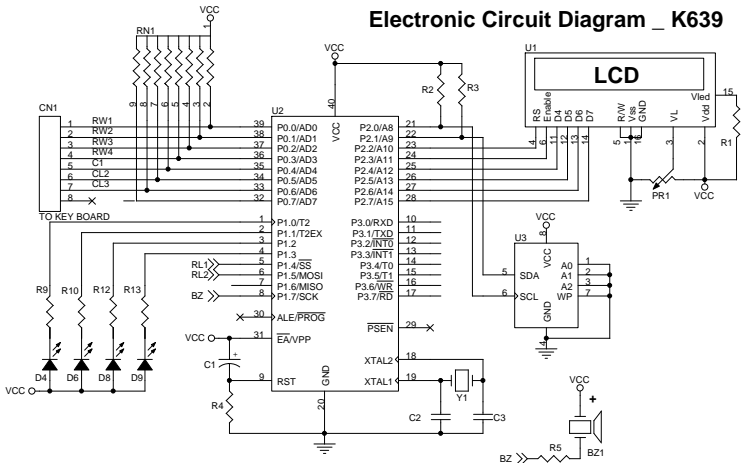
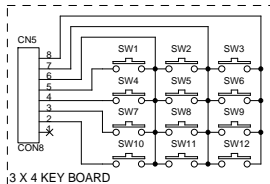
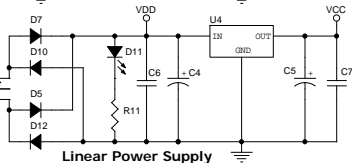
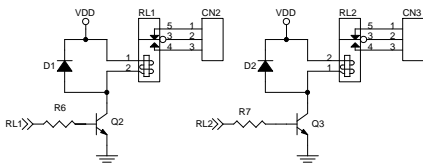

3 X 4 KEY BOARD

SECURITY ACCESS CONTROL SYSTEM